



Compagnia Tecnica Motori S.p.A.

I-20090 Cesano Boscone (Mi)
Via Magellano, 1
Tel. +39 02.450581 (20 linee r.a.)
Fax +39 02.45058260 / 262

Magazzino Ricambi:
Fax diretto +39 02.45058263
www.ctm.it
e-mail: ctm@ctm.it



Black Start TRAINING MANUAL JOB 6609 REV.0

2. Alternator

2.1. Stamford (Type UC-I224D1)

STAMFORD

AC GENERATORS FROM
NEWAGE INTERNATIONAL

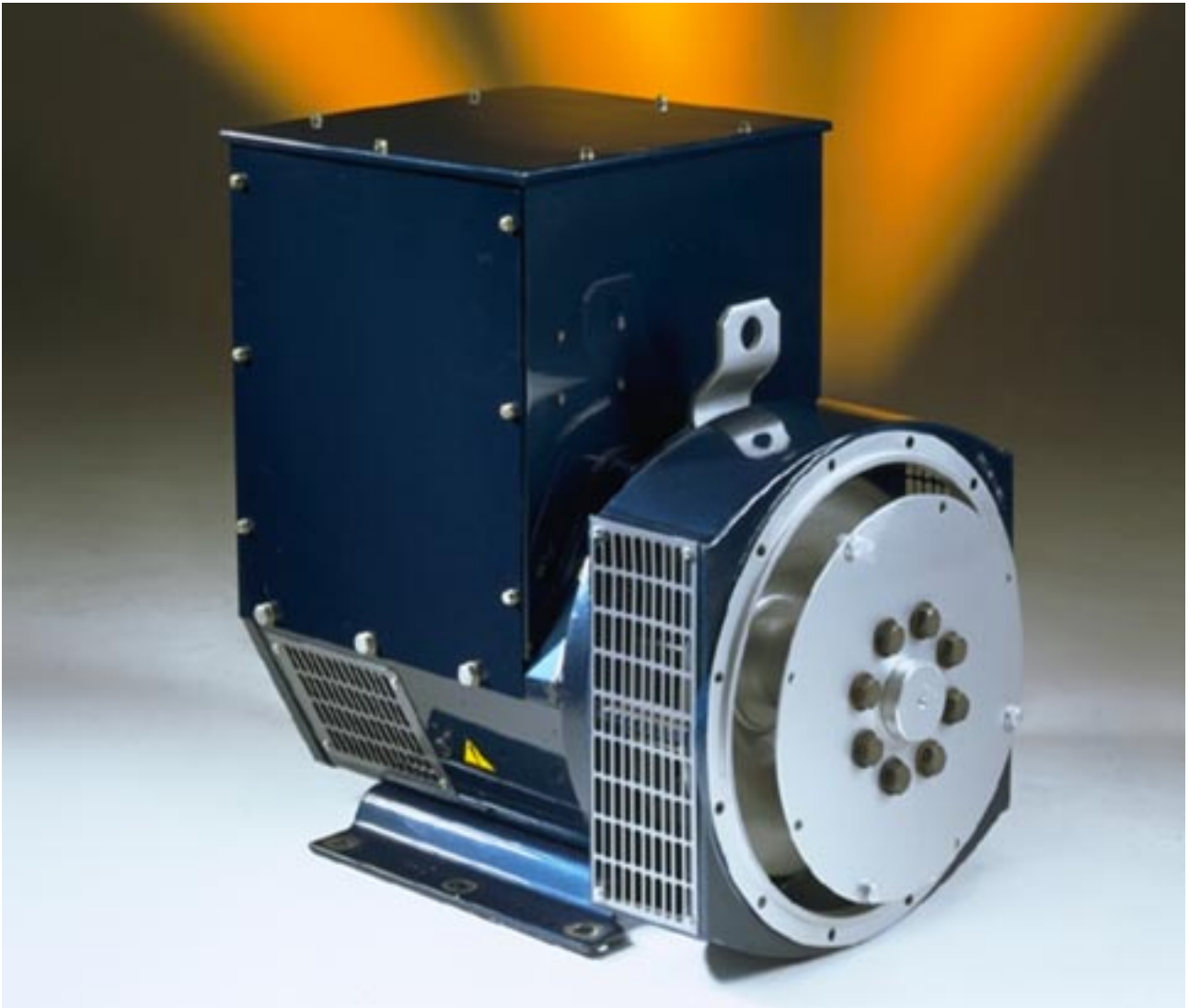

Installation, Service & Maintenance Manual

for AC generators with the following prefixes:

UCI; UCM; UCD 224 & 274 .

SAFETY PRECAUTIONS

Before operating the generating set, read the generating set operation manual and this generator manual and become familiar with it and the equipment.

SAFE AND EFFICIENT OPERATION CAN ONLY BE ACHIEVED IF THE EQUIPMENT IS CORRECTLY OPERATED AND MAINTAINED.

Many accidents occur because of failure to follow fundamental rules and precautions.

ELECTRICAL SHOCK CAN CAUSE SEVERE PERSONAL INJURY OR DEATH.

- Ensure installation meets all applicable safety and local electrical codes. Have all installations performed by a qualified electrician.
- Do not operate the generator with protective covers, access covers or terminal box covers removed.
- Disable engine starting circuits before carrying out maintenance.
- Disable closing circuits and/or place warning notices on any circuit breakers normally used for connection to the mains or other generators, to avoid accidental closure.

Observe all **IMPORTANT, CAUTION, WARNING,** and **DANGER** notices, defined as:

Important ! Important refers to hazard or unsafe method or practice which can result in product damage or related equipment damage.

Caution ! Caution refers to hazard or unsafe method or practice which can result in product damage or personal injury.



Warning !

Warning refers to a hazard or unsafe method or practice which **CAN** result in severe personal injury or possible death.



Danger !

Danger refers to immediate hazards which **WILL** result in severe personal injury or death.

FOREWORD

The function of this book is to provide the user of the Stamford generator with an understanding of the principles of operation, the criteria for which the generator has been designed, and the installation and maintenance procedures. Specific areas where the lack of care or use of incorrect procedures could lead to equipment damage and/or personal injury are highlighted, with **WARNING** and/or **CAUTION** notes, and it is **IMPORTANT** that the contents of this book are read and understood before proceeding to fit or use the generator.

The Service, Sales and technical staff of Newage International are always ready to assist and reference to the company for advice is welcomed.



Warning !

Incorrect installation, operation, servicing or replacement of parts can result in severe personal injury or death, and/or equipment damage.
Service personnel must be qualified to perform electrical and mechanical service.

EC DECLARATION OF INCORPORATION

All Stamford generators are supplied with a declaration of incorporation for the relevant EC legislation, typically in the form of a label as below.

○

EC DECLARATION OF INCORPORATION

IN ACCORDANCE WITH THE SUPPLY OF MACHINERY (SAFETY) REGULATIONS 1992
AND THE SUPPLY OF MACHINERY (SAFETY) (AMENDMENT) REGULATIONS 1994
IMPLEMENTING THE EC MACHINERY DIRECTIVE 89/392/EEC AS AMENDED BY 91/368/EEC.

THIS STAMFORD A.C. GENERATOR WAS
MANUFACTURED BY OR ON BEHALF OF
NEWAGE INTERNATIONAL LTD
BARNACK ROAD STAMFORD LINCOLNSHIRE ENGLAND.

THIS COMPONENT MACHINERY MUST NOT BE PUT INTO SERVICE UNTIL THE
MACHINERY INTO WHICH IT IS TO BE INCORPORATED HAS BEEN DECLARED IN
CONFORMITY WITH THE PROVISIONS OF THE SUPPLY OF MACHINERY (SAFETY)
REGULATIONS 1995/MACHINERY DIRECTIVE.

FOR AND ON BEHALF OF NEWAGE INTERNATIONAL LIMITED

NAME: LAWRENCE HAYDOCK
POSITION: TECHNICAL DIRECTOR
SIGNATURE:

THIS COMPONENT MACHINERY CARRIES THE CE MARK FOR COMPLIANCE WITH THE STATUTORY
REQUIREMENTS FOR THE IMPLEMENTATION OF THE FOLLOWING DIRECTIVES

WARNING! The EMC Directive 89/336/EEC
This Component Machinery shall not be used in the Residential, Commercial and
Light Industrial environment unless it also conforms to the relevant standard
(EN 50081 - 1) REFER TO FACTORY FOR DETAILS

ii) The Low Voltage Directive 73/23/EEC as amended by 93/68/EEC

Under the EC Machinery Directive section 1.7.4. It is the responsibility of the generator set builder to ensure the generator identity is clearly displayed on the front cover of this book.



ELECTROMAGNETIC COMPATIBILITY

Additional Information

European Union

Council Directive 89/336/EEC

For installations within the European Union, electrical products must meet the requirements of the above directive, and Newage ac generators are supplied on the basis that:

- They are to be used for power-generation or related function.
- They are to be applied in one of the following environments:

Portable (open construction - temporary site supply)
Portable (enclosed - temporary site supply)
Containerised (temporary or permanent site supply)
Ship-borne below decks (marine auxiliary power)
Commercial vehicle (road transport / refrigeration etc)
Rail transport (auxiliary power)
Industrial vehicle (earthmoving, cranes etc)
Fixed installation (industrial - factory / process plant)
Fixed installation (residential, commercial and light industrial - home / office / health)
Energy management (Combined heat and power and/or peak lopping)
Alternative energy schemes

- The standard generators are designed to meet the 'industrial' emissions and immunity standards. Where the generator is required to meet the residential, commercial and light industrial emissions and immunity standards reference should be made to Newage document reference N4/X/011, as additional equipment may be required.
- The installation earthing scheme involves connection of the generator frame to the site protective earth conductor using a minimum practical lead length.
- Maintenance and servicing with anything other than factory supplied or authorised parts will invalidate any Newage liability for EMC compliance.
- Installation, maintenance and servicing is carried out by adequately trained personnel fully aware of the requirements of the relevant EC directives.

CONTENTS

SAFETY PRECAUTIONS

FOREWORD			1
CONTENTS			2&3
SECTION 1		INTRODUCTION	4
	1.1	INTRODUCTION	4
	1.2	DESIGNATION	4
	1.3	SERIAL NUMBER LOCATION AND IDENTITY NUMBER LOCATION	4
	1.4	RATING PLATE AND CE MARKING	4
SECTION 2		PRINCIPLE OF OPERATION	5
	2.1	SELF-EXCITED AVR CONTROLLED GENERATORS	5
	2.2	PERMANENT MAGNET GENERATOR (PMG) EXCITED - AVR CONTROLLED GENERATORS	5
	2.3	AVR ACCESSORIES	5
	2.4	TRANSFORMER CONTROLLED GENERATORS	5
SECTION 3		APPLICATION OF THE GENERATOR	6
SECTION 4		INSTALLATION - PART 1	8
	4.1	LIFTING	8
	4.2	ASSEMBLY	8
	4.2.1	NO FOOT OPTION	8
	4.2.2	TWO BEARING GENERATORS	9
	4.2.3	SINGLE BEARING GENERATORS	9
	4.3	EARTHING	9
	4.4	PRE-RUNNING CHECKS	9
	4.4.1	INSULATION CHECK	9
	4.4.2	DIRECTION OF ROTATION	10
	4.4.3	VOLTAGE AND FREQUENCY	10
	4.4.4	AVR SETTINGS	10
	4.4.4.1	TYPE SX460 AVR	10
	4.4.4.2	TYPE SX440 AVR	10
	4.4.4.3	TYPE SX421 AVR	11
	4.4.4.4	TYPE MX341 AVR	11
	4.4.4.5	TYPE MX321 AVR	11
	4.4.5	TRANSFORMER CONTROLLED EXCITATION SYSTEM (Series 5)	12
	4.5	GENERATOR SET TESTING	12
	4.5.1	TEST METERING/CABLING	12
	4.6	INITIAL START-UP	12
	4.7	LOAD TESTING	13
	4.7.1	AVR CONTROLLED GENERATORS - AVR ADJUSTMENTS	13
	4.7.1.1	UFRO (Under Frequency Roll Off) (AVR Types SX460, SX440, SX421, MX341 and MX321)	13
	4.7.1.2	EXC TRIP (Excitation Trip)	14
	4.7.1.3	OVER/V (Over Voltage)	14
	4.7.1.4	TRANSIENT LOAD SWITCHING ADJUSTMENTS	14
	4.7.1.5	RAMP BUILD UP TIME	15
	4.7.2	TRANSFORMER CONTROLLED GENERATORS - TRANSFORMER ADJUSTMENT	15
	4.8	ACCESSORIES	15
SECTION 5		INSTALLATION - PART 2	16
	5.1	GENERAL	16
	5.2	GLANDING	16
	5.3	EARTHING	16
	5.4	PROTECTION	16
	5.5	COMMISSIONING	16

CONTENTS

SECTION 6	ACCESSORIES	17
6.1	REMOTE VOLTAGE ADJUST (ALL AVR TYPES)	17
6.2	PARALLEL OPERATION	17
6.2.1	DROOP	17
6.2.1.1	SETTING PROCEDURE	18
6.2.2	ASTATIC CONTROL	18
6.3	MANUAL VOLTAGE REGULATOR (MVR) - MX341 and MX321 AVR	18
6.4	OVERVOLTAGE DE-EXCITATION BREAKER SX421 and MX321 AVR	18
6.4.1	RESETTING THE BREAKER	19
6.5	CURRENT LIMIT - MX321 AVR	19
6.5.1	SETTING PROCEDURE	19
6.6	POWER FACTOR CONTROLLER (PFC3)	20
SECTION 7	SERVICE AND MAINTENANCE	21
7.1	WINDING CONDITION	21
7.1.1	WINDING CONDITION ASSESSMENT	21
7.1.2	METHODS OF DRYING OUT GENERATORS	21
7.2	BEARINGS	23
7.3	AIR FILTERS	23
7.3.1	CLEANING PROCEDURE	23
7.4	FAULT FINDING	23
7.4.1	SX460 AVR - FAULT FINDING	23
7.4.2	SX440 AVR - FAULT FINDING	24
7.4.3	SX421 AVR - FAULT FINDING	24
7.4.4	TRANSFORMER CONTROL - FAULT FINDING	24
7.4.5	MX341 AVR - FAULT FINDING	25
7.4.6	MX321 AVR - FAULT FINDING	25
7.4.7	RESIDUAL VOLTAGE CHECK	26
7.5	SEPARATE EXCITATION TEST PROCEDURE	26
7.5.1	GENERATOR WINDINGS, ROTATING DIODES and PERMANENT MAGNET GENERATOR (PMG)	26
7.5.1.1	BALANCED MAIN TERMINAL VOLTAGES	26
7.5.1.2	UNBALANCED MAIN TERMINAL VOLTAGES	27
7.5.2	EXCITATION CONTROL TEST	27
7.5.2.1	AVR FUNCTION TEST	27
7.5.2.2	TRANSFORMER CONTROL	28
7.5.3	REMOVAL AND REPLACEMENT OF COMPONENT ASSEMBLIES	28
7.5.3.1	REMOVAL OF PERMANENT MAGNET GENERATOR (PMG)	28
7.5.3.2	REMOVAL OF BEARINGS	28
7.5.3.3	REMOVAL OF ENDBRACKET AND EXCITER STATOR	28
7.5.3.4	REMOVAL OF THE ROTOR ASSEMBLY	29
7.6	RETURNING TO SERVICE	29
SECTION 8	SPARES AND AFTER SALES SERVICE	30
8.1	RECOMMENDED SPARES	30
8.2	AFTER SALES SERVICE	30
SECTION 9	PARTS IDENTIFICATION	32
	TYPICAL SINGLE BEARING GENERATOR (Fig. 11)	33
	TYPICAL TWO BEARING GENERATOR (Fig. 12)	35
	TYPICAL TWO BEARING (SERIES 5) GENERATOR (Fig. 13)	37
	ROTATING RECTIFIER ASSEMBLY (Fig. 14)	38

SECTION 1

INTRODUCTION

1.1 INTRODUCTION

The UC22/27 range of generators is of brushless rotating field design, available up to 660V/50Hz (1500 rpm) or 60Hz (1800 rpm), and built to meet BS5000 Part 3 and international standards.

All the UC22/27 range are self-excited with excitation power derived from the main output windings, using either the SX460/SX440/SX421 AVR. The UC22 is also available with specific windings and a transformer controlled excitation system.

A permanent magnet generator (PMG) powered excitation system is available as an option using either the MX341 or MX321 AVR.

Detailed specification sheets are available on request.

1.2 DESIGNATION

U	C	.	I	2	2	4	C	2
U	C	.	M	2	7	4	C	2

GENERATOR TYPE UC

SPECIFIC TYPE

INDUSTRIAL = (I) OR MARINE = (M)

SHAFT HEIGHT IN CM ON BC/UC

NUMBER OF POLES 2, 4, OR 6

CORE LENGTH

NUMBER OF BEARINGS 1 OR 2

1.3 SERIAL NUMBER LOCATION AND IDENTITY NUMBER LOCATION

Each generator is metal stamped with it's own unique serial number, the location of this number is described below.

UCI and UCM generators have their serial number stamped into the upper section of the drive end frame to end bracket adaptor ring, shown as item 31 in the parts lists at the back of this book.

UCD generators have their serial number stamped into the top of the drive end adaptor /fan shroud casting. If for any reason this casting is removed, it is imperative that care is taken to refit it to the correct generator to ensure correct identification is retained.

Inside the terminal box two adhesive rectangular labels have been fixed, each carrying the generators unique identity number. One label has been fixed to the inside of the terminal box sheet metal work, and the second label fixed to the main frame of the generator.

1.4 RATING PLATE

The generator has been supplied with a self adhesive rating plate label to enable fitting after final assembly and painting.

It is intended that this label will be stuck to the outside of the terminal box on the left hand side when viewed from the N.D.E. To assist with squarely positioning the label, location protrusions have been made in the sheet metalwork.

A CE Mark label is also supplied loose for fitment after final assembly and painting. This should be attached to an external surface of the Generator at a suitable location where it will not be obscured by the customer's wiring or other fittings.

The surface in the area where a label is to be stuck must be flat, clean, and any paint finish be fully dry before attempting to attach label. Recommended method for attaching label is peel and fold back sufficient of the backing paper to expose some 20 mm of label adhesive along the edge which is to be located against the sheet metal protrusions. Once this first section of label has been carefully located and stuck into position the backing paper can be progressively removed, as the label is pressed down into position. The adhesive will achieve a permanent bond in 24 hours.

SECTION 2

PRINCIPLE OF OPERATION

2.1 SELF-EXCITED AVR CONTROLLED GENERATORS

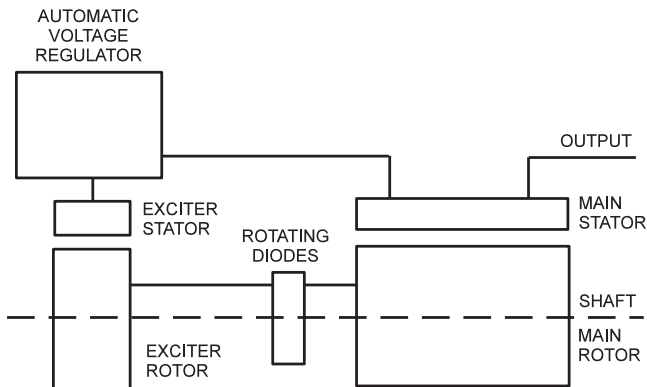

The main stator provides power for excitation of the exciter field via the SX460 (SX440 or SX421) AVR which is the controlling device governing the level of excitation provided to the exciter field. The AVR responds to a voltage sensing signal derived from the main stator winding. By controlling the low power of the exciter field, control of the high power requirement of the main field is achieved through the rectified output of the exciter armature.

The SX460 or SX440 AVR senses average voltage on two phases ensuring close regulation. In addition it detects engine speed and provides voltage fall off with speed, below a pre-selected speed (Hz) setting, preventing over-excitation at low engine speeds and softening the effect of load switching to relieve the burden on the engine.

The SX421 AVR in addition to the SX440 features has three phase rms sensing and also provides for over voltage protection when used in conjunction with an external circuit breaker (switchboard mounted).

2.2 PERMANENT MAGNET GENERATOR (PMG) EXCITED - AVR CONTROLLED GENERATORS

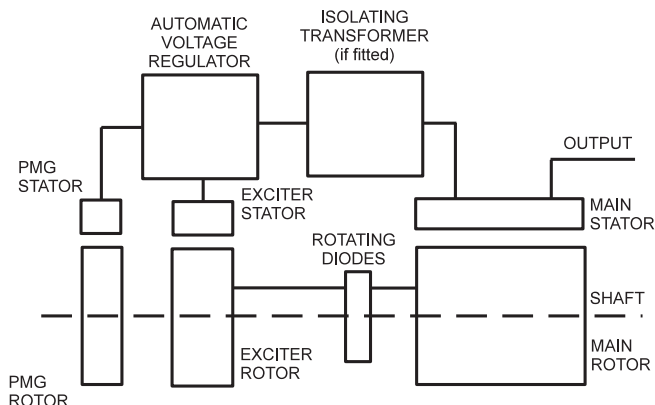

The permanent magnet generator (PMG) provides power for excitation of the exciter field via the AVR (MX341 or MX321) which is the controlling device governing the level of excitation provided to the exciter field. The AVR responds to a voltage sensing signal derived, via an isolating transformer in the case of MX321 AVR, from the main stator winding. By controlling the low power of the exciter field, control of the high power requirement of the main field is achieved through the rectified output of the exciter armature.

The PMG system provides a constant source of excitation power irrespective of main stator loading and provides high motor starting capability as well as immunity to waveform distortion on the main stator output created by non linear loads, e.g. thyristor controlled dc motor.

The MX341 AVR senses average voltage on two phases ensuring close regulation. In addition it detects engine speed and provides an adjustable voltage fall off with speed, below a pre-selected speed (Hz) setting, preventing over-excitation at low engine speeds and softening the effect of load switching to relieve the burden on the engine. It also provides over-excitation protection which acts following a time delay, to de-excite the generator in the event of excessive exciter field voltage.

The MX321 provides the protection and engine relief features of the MX341 and additionally incorporates 3 phase rms sensing and over-voltage protection.

The detailed function of all the AVR circuits is covered in the load testing (subsection 4.7).

2.3 AVR ACCESSORIES

The SX440, SX421, MX341 and MX321 AVRs incorporate circuits which, when used in conjunction with accessories, can provide for parallel operation either with 'droop' or 'astatic' control, VAR/PF control and in the case of the MX321 AVR, short circuit current limiting.

Function and adjustment of the accessories which can be fitted inside the generator terminal box are covered in the accessories section of this book.

Separate instructions are provided with other accessories available for control panel mounting.

2.4 TRANSFORMER CONTROLLED GENERATORS

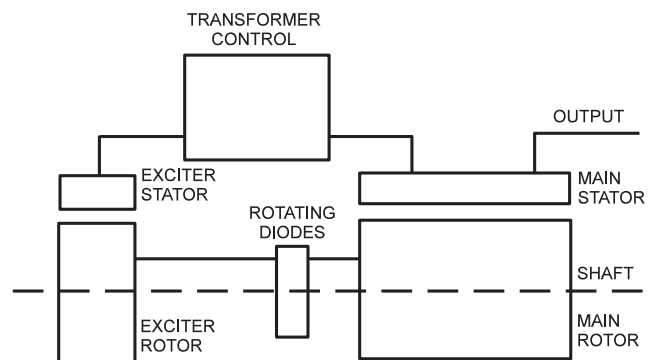

The main stator provides power for excitation of the exciter field via a transformer rectifier unit. The transformer combines voltage and current elements derived from the main stator output to form the basis of an open-loop control system, which is self regulating in nature. The system inherently compensates for load current magnitude and power factor and provides short circuit maintenance in addition to a good motor starting performance.

Three phase generators normally have a three phase transformer control for improved performance with unbalanced loads but a single phase transformer option is available.

No accessories can be provided with this control system.

SECTION 3

APPLICATION OF THE GENERATOR

The generator is supplied as a component part for installation in a generating set. It is not, therefore, practicable to fit all the necessary warning/hazard labels during generator manufacture. The additional labels required are packaged with this Manual, together with a drawing identifying their locations. (See below).

The generators are of air-ventilated screen protected drip-proof design and are not suitable for mounting outdoors unless adequately protected by the use of canopies. Anti-condensation heaters are recommended during storage and for standby duty to ensure winding insulation is maintained in good condition.

When installed in a closed canopy it must be ensured that the ambient temperature of the cooling air to the generator does not exceed that for which the generator has been rated.

The canopy should be designed such that the engine air intake to the canopy is separated from the generator intake, particularly where the radiator cooling fan is required to draw air into the canopy. In addition the generator air intake to the canopy should be designed such that the ingress of moisture is prohibited, preferably by use of a 2 stage filter.

The air intake/outlet must be suitable for the air flow given in the following table with additional pressure drops less than or equal to those given below:

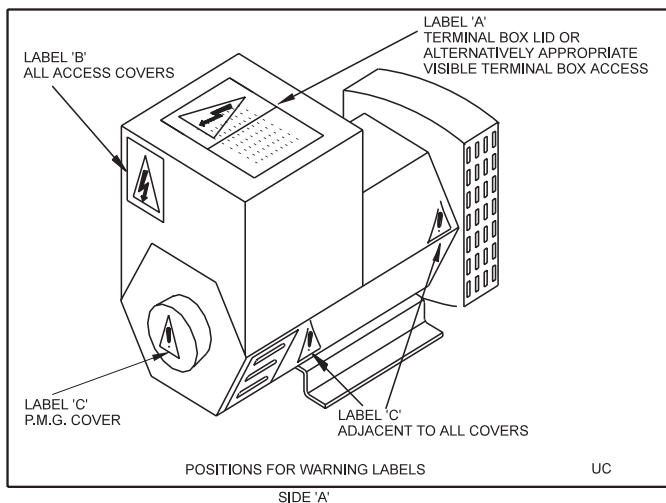

Frame	Air Flow		Additional (intake/outlet) Pressure Drop
	50Hz	60Hz	
UC22	0.216m ³ /sec	0.281m ³ /sec	6mm water gauge
	458cfm	595cfm	0.25"
UCD22	0.25m ³ /sec	0.31m ³ /sec	6mm water gauge
	530cfm	657cfm	0.25"
UC27	0.514m ³ /sec	0.617m ³ /sec	6mm water gauge
	1090cfm	1308cfm	0.25"
UCD27	0.58m ³ /sec	0.69m ³ /sec	6mm water gauge
	1230cfm	1463cfm	0.25"

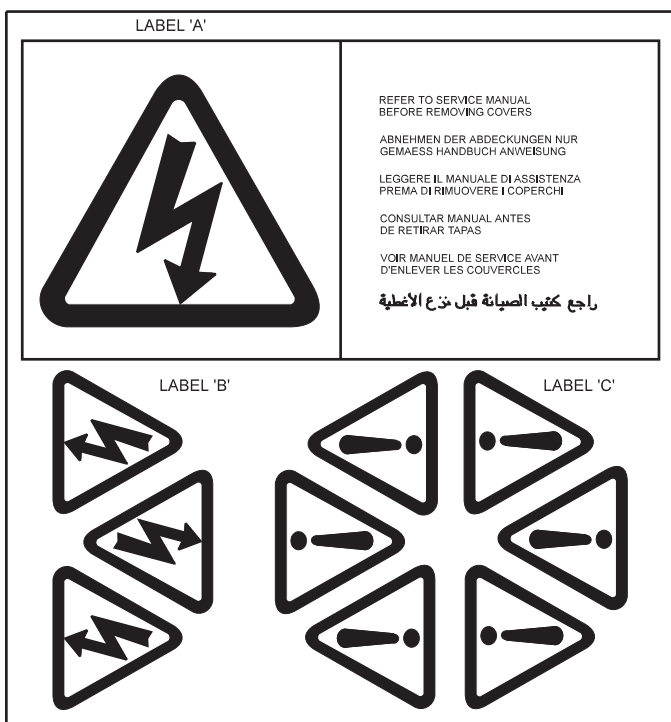

Important ! Reduction in cooling air flow or inadequate protection to the generator can result in damage and/or failure of windings.

Dynamic balancing of the generator rotor assembly has been carried out during manufacture in accordance with BS 6861 Part 1 Grade 2.5 to ensure vibration limits of the generator are in accordance with BS 4999 Part 142.

The main vibration frequencies produced by the generator are as follows:-

4 pole	1500 rpm	25 Hz
4 pole	1800 rpm	30 Hz

However, vibrations induced by the engine are complex and contain frequencies of 1.5, 3, 5 or more times the fundamental frequency of vibration. These induced vibrations can result in generator vibration levels higher than those derived from the generator itself. It is the responsibility of the generating set designer to ensure that the alignment and stiffness of the bedplate and mountings are such that the vibration limits of BS5000 Part 3 are not exceeded.

It is the responsibility of the generating set manufacturer to ensure that the correct labels are fitted, and are clearly visible.

The generators have been designed for use in a maximum ambient temperature of 40°C and altitude less than 1000m above sea level in accordance with BS5000.

Ambients in excess of 40°C and altitudes above 1000m can be tolerated with reduced ratings - refer to the generator nameplate for rating and ambient. In the event that the generator is required to operate in an ambient in excess of the nameplate value or at altitudes in excess of 1000 metres above sea level, refer to the factory.

In standby applications where the running time is limited and reduced life expectancy is accepted, higher levels than specified in BS5000 can be tolerated, up to a maximum of 18mm/sec.

Two bearing generators open coupled require a substantial bedplate with engine/generator mounting pads to ensure a good base for accurate alignment. Close coupling of engine to generator can increase the overall rigidity of the set. For the purposes of establishing set design the bending moment at the engine flywheel housing to generator adaptor interface should not exceed 1000ft.lb. (140 kgm). A flexible coupling, designed to suit the specific engine/generator combination, is recommended to minimise torsional effects.

Belt driven applications of two bearing generators require the pulley diameter and design to be such that the side load or force applied to the shaft is central to the extension and does not exceed the values given in the table below:-

Frame	Side Load		Shaft extension mm
	kgf	N	
UC22	408	4000	110
UC27	510	5000	140

In instances where shaft extensions greater than specified in the table have been supplied reference must be made to the factory for appropriate loadings.

Alignment of single bearing generators is critical and vibration can occur due to the flexing of the flanges between the engine and generator. As far as the generator is concerned the maximum bending moment at this point must not exceed 1000ft.lb. (140 kgm). A substantial bedplate with engine/generator mounting pads is required.

It is expected that the generator will be incorporated into a generating set operating in an environment, where the maximum shock load experienced by the generator will not exceed 3g. in any plane. If shock loads in excess of 3g are to be encountered, anti-vibration mountings must be incorporated into the generating set to ensure they absorb the excess.

The maximum bending moment of the engine flange must be checked with the engine manufacturer.

Generators can be supplied without a foot, providing the option for customers own arrangement. See SECTION 4.2.1 for assembly procedure.

Torsional vibrations occur in all engine-driven shaft systems and may be of a magnitude to cause damage at certain critical speeds. It is therefore necessary to consider the torsional vibration effect on the generator shaft and couplings.

It is the responsibility of the generator set manufacturer to ensure compatibility, and for this purpose drawings showing the shaft dimensions and rotor inertias are available for customers to forward to the engine supplier. In the case of single bearing generators coupling details are included.

Important ! Torsional incompatibility and/or excessive vibration levels can cause damage or failure of generator and/or engine components.

The terminal box is constructed with removable panels for easy adaptation to suit specific glanding requirements. Within the terminal box there are insulated terminals for line and neutral connections and provision for earthing. Additional earthing points are provided on the generator feet.

The neutral is NOT connected to the frame.

The main stator winding has leads brought out to the terminals in the terminal box.



Warning ! No earth connections are made on the generator and reference to site regulations for earthing must be made. Incorrect earthing or protection arrangements can result in personal injury or death.

Fault current curves (decrement curves), together with generator reactance data, are available on request to assist the system designer to select circuit breakers, calculate fault currents and ensure discrimination within the load network.



Warning ! Incorrect installation, service or replacement of parts can result in severe personal injury or death, and/or equipment damage. Service personnel must be qualified to perform electrical and mechanical service.

SECTION 4

INSTALLATION - PART 1

4.1 LIFTING





Warning ! Incorrect lifting or inadequate lifting capacity can result in severe personal injury or equipment damage. **MINIMUM LIFTING CAPACITY REQUIRED IS 750Kg.** Generator lifting lugs should **NOT** be used for lifting the complete generator set.

Two lifting lugs are provided for use with a shackle and pin type lifting aid. Chains of suitable length and lifting capacity must be used. Lifting points are designed to be as close to the centre of gravity of the generator as possible, but due to design restrictions it is not possible to guarantee that the generator frame will remain horizontal while lifting. Care is therefore needed to avoid personal injury or equipment damage. The correct lifting arrangement is shown on the label attached to the lifting lug. (See sample below).

IMPORTANT

REFER TO SERVICE MANUAL BEFORE REMOVING COVERS. IT IS THE GENERATOR SET MANUFACTURER'S RESPONSIBILITY TO FIT THE SELF ADHESIVE WARNING LABELS SUPPLIED WITH THE GENERATOR. THE LABEL SHEET CAN BE FOUND WITH THE INSTRUCTION BOOK.



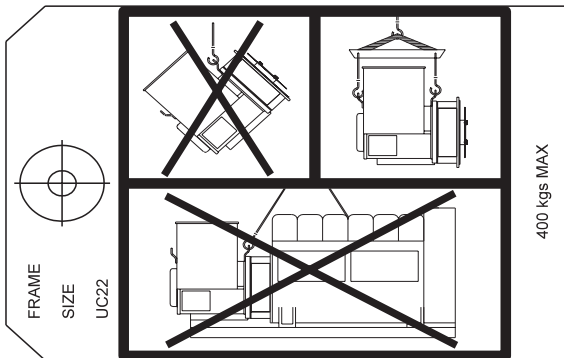

Single bearing generators are supplied fitted with a rotor retaining bar at the non-drive end of the shaft.

To remove retaining bar:

1. Remove the four screws holding the sheet metal cover at the non drive end and remove cover
2. Remove central bolt holding the retaining bar to the shaft
3. Refit sheet metal cover.

Once the bar is removed, to couple the rotor to engine, the rotor is free to move in the frame, and care is needed during coupling and alignment to ensure the frame is kept in the horizontal plane.

Generators fitted with a PMG excitation system are not fitted with retaining bar. Refer to frame designation to verify generator type (subsection 1.2)

4.2 ASSEMBLY

During the assembly of the generator to the engine it will be necessary firstly to carefully align, then rotate, the combined generator rotor - engine crankshaft assembly, as part of the construction process, to allow location, insertion and tightening of the coupling bolts. This requirement to rotate the combined assemblies exists for both single and two bearing units.

During the assembly of single bearing units it is necessary to align the generator's coupling holes with the engine flywheel holes; it is suggested that two diametrically opposite location dowel pins are fitted to the engine flywheel, over which the generator coupling can slide into final location into the engine flywheel spigot recess. The dowels must be removed and replaced by coupling bolts before the final bolt tightening sequence.

While fitting and tightening the coupling bolts it will be necessary to rotate the engine crankshaft - generator rotor assembly. Care should be taken to ensure that rotation is carried out in an approved manner that ensures safe working practice when reaching inside the machine to insert or tighten coupling bolts, and that no component of the assembly is damaged by non-approved methods of assembly rotation.

Engine manufacturers have available a proprietary tool or facility designed to enable manual rotation of the crankshaft assembly. This must always be used, having been engineered as an approved method of assembly rotation, engaging the manually driven pinion with the engine flywheel starter ring-gear.

Caution ! Before working inside the generator, during the aligning and fitting of coupling bolts, care should be taken to lock the assembly to ensure there is no possibility of rotational movement.

4.2.1 NO FOOT OPTION

Generators can be supplied without a foot providing the option for customers own arrangement.

For details of mounting this arrangement, see the general arrangement drawing supplied with the generator. Alternatively refer to Newage International for a copy of the latest general arrangement drawing showing the 'NO FOOT OPTION' appropriate to your generator.

4.2.2 TWO BEARING GENERATORS

A flexible coupling should be fitted and aligned in accordance with the coupling manufacturer's instruction.

If a close coupling adaptor is used the alignment of machined faces must be checked by offering the generator up to the engine. Shim the generator feet if necessary. Ensure adaptor guards are fitted after generator/engine assembly is complete. Open coupled sets require a suitable guard, to be provided by the set builder.

In the case of belt driven generators, ensure alignment of drive and driven pulleys to avoid axial load on the bearings. Screw type tensioning devices are recommended to allow accurate adjustment of belt tension whilst maintaining pulley alignment. Side loads should not exceed values given in SECTION 3.

Belt and pulley guards must be provided by the set builder.

Important ! Incorrect belt tensioning will result in excessive bearing wear.

Caution ! Incorrect guarding and/or generator alignment can result in personal injury and/or equipment damage.

4.2.3 SINGLE BEARING GENERATORS

Alignment of single bearing generators is critical. If necessary shim the generator feet to ensure alignment of the machined surfaces.

For transit and storage purposes the generator frame spigot and rotor coupling plates have been coated with a rust preventative. This MUST BE removed before assembly to engine.

A practical method for removal of this coating is to clean the mating surface areas with a de-greasing agent based on a petroleum solvent.

Care should be taken not to allow any cleaning agent to come into prolonged contact with skin.

The sequence of assembly to the engine should generally be as follows:

1. On the engine check the distance from the coupling mating face on the flywheel to the flywheel housing mating face. This should be within +/-0.5mm of nominal dimension. This is necessary to ensure that a thrust is not applied to the a.c. generator bearing or engine bearing.
2. Check that the bolts securing the flexible plates to the coupling hub are tight and locked into position. Torque tightening is 24.9kgfm (244Nm; 180 lb ft).
- 2a. **UCD224 Only**
Torque tightening is 15.29 kgfm (150Nm; 110 lb ft).

3. Remove covers from the drive end of the generator to gain access to coupling and adaptor bolts.
4. Check that coupling discs are concentric with adaptor spigot. This can be adjusted by the use of tapered wooden wedges between the fan and adaptor. Alternatively the rotor can be suspended by means of a rope sling through the adaptor opening.
5. Offer the a.c. generator to engine and engage both coupling discs and housing spigots at the same time, finally pulling home by using the housing and coupling bolts. Use heavy gauge washers between bolt head and discs on disc to flywheel bolts.
6. Tighten coupling disc to flywheel. Refer to engine manual for torque setting of disc to flywheel bolts.
7. Remove wooden wedges.

Caution ! Incorrect guarding and/or generator alignment can result in personal injury and/or equipment damage.

4.3 EARTHING

The generator frame should be solidly bonded to the generating set bedplate. If antivibration mounts are fitted between the generator frame and its bedplate a suitably rated earth conductor (normally one half of the cross sectional area of the main line cables) should bridge across the antivibration mount.



Warning !

Refer to local regulations to ensure that the correct earthing procedure has been followed.

4.4 PRE-RUNNING CHECKS

4.4.1 INSULATION CHECK

Before starting the generating set, both after completing assembly and after installation of the set, test the insulation resistance of windings.

The AVR should be disconnected during this test.

A 500V Megger or similar instrument should be used. Disconnect any earthing conductor connected between neutral and earth and megger an output lead terminal U, V or W to earth. The insulation resistance reading should be in excess of 5MΩ to earth. Should the insulation resistance be less than 5MΩ the winding must be dried out as detailed in the Service and Maintenance section of this Manual.

Important ! The windings have been H.V. tested during manufacture and further H.V. testing may degrade the insulation with consequent reduction in operating life. Should it be necessary to demonstrate H.V. testing, for customer acceptance, the tests must be carried out at reduced voltage levels i.e. Test Voltage= 0.8 (2 X Rated Voltage + 1000)

4.4.2 DIRECTION OF ROTATION

The generator is supplied to give a phase sequence of U V W with the generator running clockwise looking at the drive end (unless otherwise specified at the time of ordering). If the generator phase rotation has to be reversed after the generator has been despatched apply to factory for appropriate wiring diagrams.

UCI224, UCI274, UCM224, UCM274

Machines are fitted with bi-directional fans and are suitable for running in either direction of rotation.

UCD224, UCD274

Machines are fitted with uni-directional fans and are suitable for running in one direction only.

4.4.3 VOLTAGE AND FREQUENCY

Check that the voltage and frequency levels required for the generating set application are as indicated on the generator nameplate.

Three phase generators normally have a 12 ends out reconnectable winding. If it is necessary to reconnect the stator for the voltage required, refer to diagrams in the back of this manual.

4.4.4 AVR SETTINGS

To make AVR selections and adjustments remove the AVR cover and refer to 4.4.4.1, 4.4.4.2, 4.4.4.3, 4.4.4.4 or 4.4.4.5 depending upon type of AVR fitted. Reference to the generator nameplate will indicate AVR type (SX460, SX440, SX421, MX341 or MX321).

Most of the AVR adjustments are factory set in positions which will give satisfactory performance during initial running tests. Subsequent adjustment may be required to achieve optimum performance of the set under operating conditions. Refer to 'Load Testing' section for details.

4.4.4.1 TYPE SX460 AVR

The following 'jumper' connections on the AVR should be checked to ensure they are correctly set for the generating set application.

Refer to Fig. 1 for location of selection links.

1. Frequency selection

50Hz operation LINK C-50
60Hz operation LINK C-60

2. External hand trimmer selection

No external hand trimmer LINK 1-2
External hand trimmer required - REMOVE LINK 1-2 and connect trimmer across terminals 1 and 2.

3. AVR Input Selection

High voltage (220/240V) Input NO LINK
Low voltage (110/120V) Input LINK 3-4

Refer to diagram in the back of this manual to determine wiring.

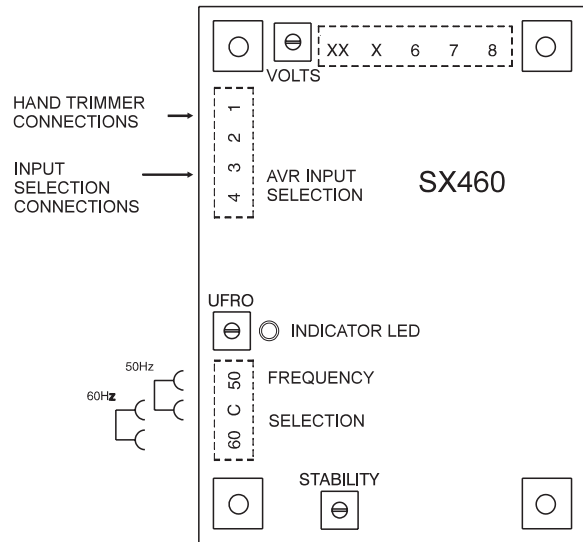

Fig. 1

4.4.4.2 TYPE SX440 AVR

The following 'jumper' connections on the AVR should be checked to ensure they are correctly set for the generating set application.

Refer to Fig. 2 for location of selection links.

1. Frequency selection terminals

50Hz operation LINK C-50
60Hz operation LINK C-60

2. Stability selection terminals

Frame UC22 LINK A-C
Frame UC27 LINK B-C

3. Sensing selection terminals

LINK 2-3
LINK 4-5
LINK 6-7

4. Excitation Interruption Link

LINK K1-K2

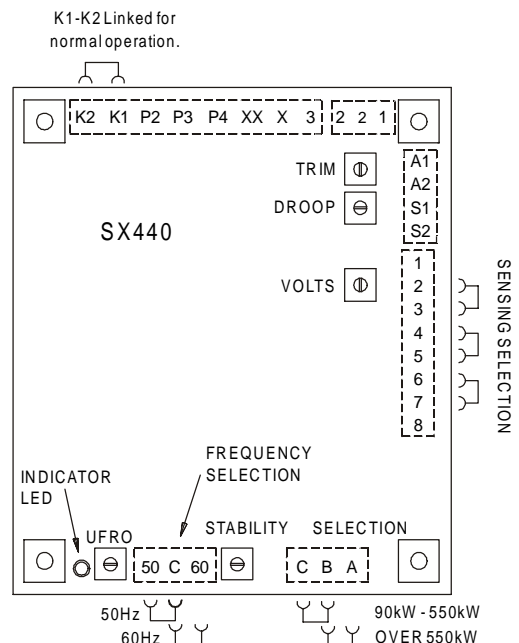

Fig. 2

4.4.4.3 TYPE SX421 AVR

The following 'jumper' connections on the AVR should be checked to ensure they are correctly set for the generating set application.

Refer to Fig. 3 for location of selection links.

1. Frequency selection terminals

- 50Hz operation LINK C-50
- 60Hz operation LINK C-60

2. Stability selection terminals

- Depending upon kW output LINK B-D
- or LINK A-C
- or LINK B-C

3. Terminals K1 - K2

Excitation circuit breaker closed

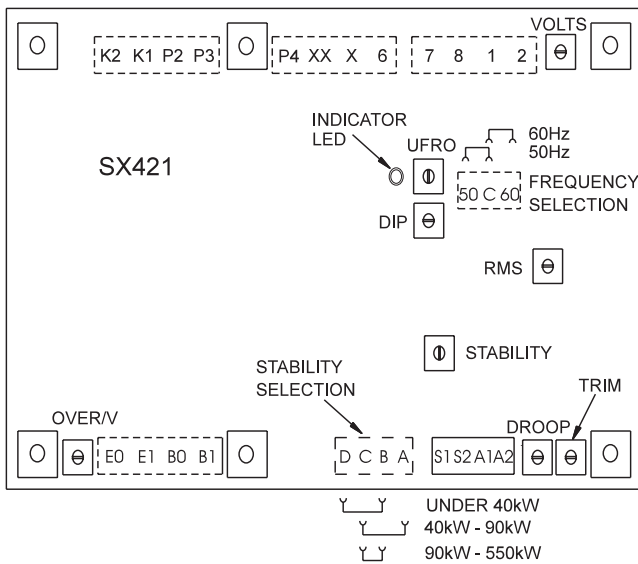

Fig. 3

4.4.4.4 TYPE MX341 AVR

The following 'jumper' connections on the AVR should be checked to ensure they are correctly set for the generating set application.

Refer to Fig. 4 for location of setting links.

1. Frequency selection terminals

- 50Hz operation LINK 2-3
- 60Hz operation LINK 1-3

2. Stability selection terminals

- Frame UC22 LINK A-C
- Frame UC27 LINK B-C

3. Sensing selection terminals *

- LINK 2-3
- LINK 4-5
- LINK 6-7

4. Excitation Interruption Link

LINK K1-K2

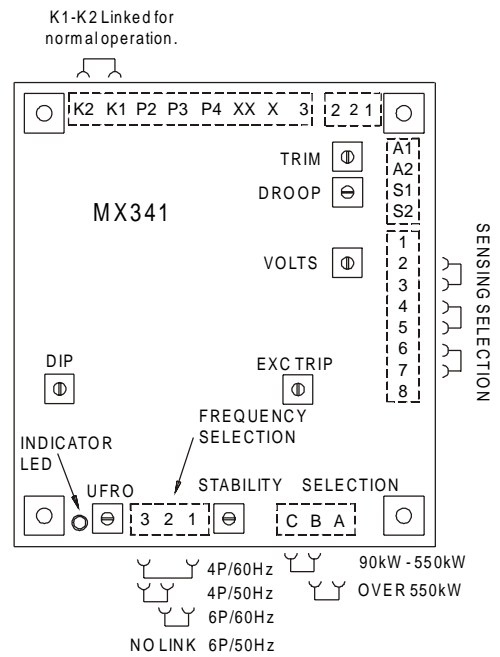

Fig. 4

4.4.4.5 TYPE MX321 AVR

The following 'jumper' connections on the AVR should be checked to ensure they are correctly set for the generating set application.

Refer to Fig. 5 for location of setting links.

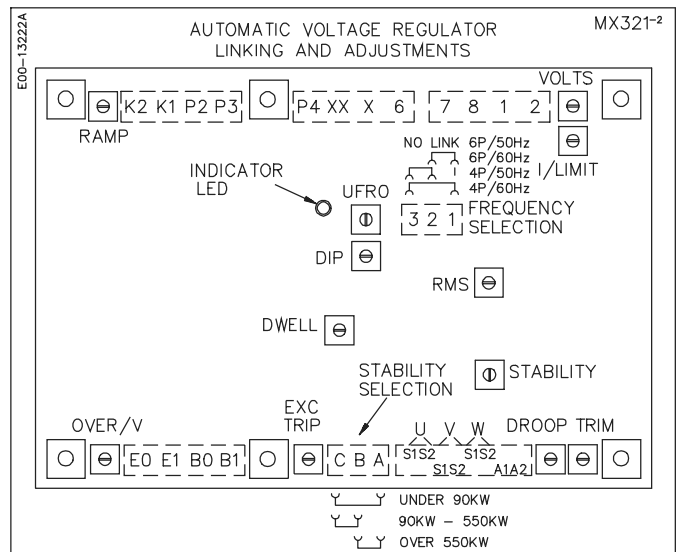

Fig. 5

1. Frequency selection terminals

- 50Hz operation LINK 2-3
- 60Hz operation LINK 1-3

2. Stability selection terminals

- Frame UC22 LINK A-C
- Frame UC27 LINK B-C

3. Terminals K1 - K2

Excitation circuit breaker closed.

If this option not fitted, K1 - K2 linked at auxiliary terminal block.

4.4.5 TRANSFORMER CONTROLLED EXCITATION SYSTEM (Series 5)

This control system is identified with the digit 5 as the last digit of the frame size quoted on the nameplate.

The excitation control is factory set for the specific voltage shown on the nameplate and requires no adjustment.

4.5 GENERATOR SET TESTING



Warning ! During testing it may be necessary to remove covers to adjust controls exposing 'live' terminals or components. Only personnel qualified to perform electrical service should carry out testing and/or adjustments.

4.5.1 TEST METERING/CABLING

Connect any instrument wiring and cabling required for initial test purposes with permanent or spring-clip type connectors.

Minimum instrumentation for testing should be line - line or line to neutral voltmeter, Hz meter, load current metering and kW meter. If reactive load is used a power factor meter is desirable.

Important ! When fitting power cables for load testing purposes, ensure cable voltage rating is at least equal to the generator rated voltage. The load cable termination should be placed on top of the winding lead termination and clamped with the nut provided.

Caution ! Check that all wiring terminations for internal or external wiring are secure, and fit all terminal box covers and guards. Failure to secure wiring and/or covers may result in personal injury and/or equipment failure.

4.6 INITIAL START-UP



Warning ! During testing it may be necessary to remove covers to adjust controls exposing 'live' terminals or components. Only personnel qualified to perform electrical service should carry out testing and/or adjustments. Refit all access covers after adjustments are completed.

On completion of generating set assembly and before starting the generating set ensure that all engine manufacturer's pre-running procedures have been completed, and that adjustment of the engine governor is such that the generator will not be subjected to speeds in excess of 125% of the rated speed.

Important ! Overspeeding of the generator during initial setting of the speed governor can result in damage to the generator rotating components.

In addition remove the AVR access cover (on AVR controlled generators) and turn VOLTS control fully anti-clockwise. Start the generating set and run on no-load at nominal frequency. Slowly turn VOLTS control potentiometer clockwise until rated voltage is reached. Refer to Fig. 6a, 6b, 6c, 6d or 6e for control potentiometer location.

Important ! Do not increase the voltage above the rated generator voltage shown on the generator nameplate.

The STABILITY control potentiometer will have been pre-set and should normally not require adjustment, but should this be required, usually identified by oscillation of the voltmeter, refer to Fig. 6a, 6b, 6c, 6d or 6e for control potentiometer location and proceed as follows:-

1. Run the generating set on no-load and check that speed is correct and stable
2. Turn the STABILITY control potentiometer clockwise, then turn slowly anti-clockwise until the generator voltage starts to become unstable.

The correct setting is slightly clockwise from this position (i.e. where the machine volts are stable but close to the unstable region).

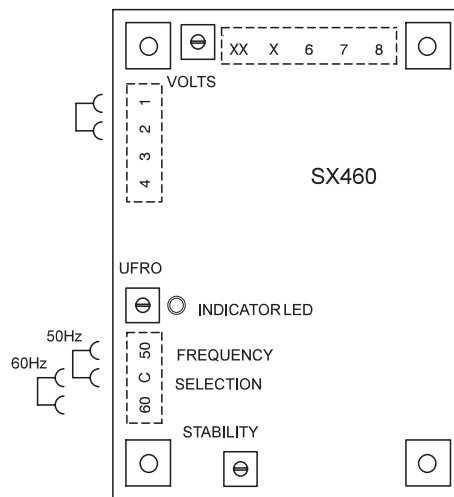

Fig. 6a

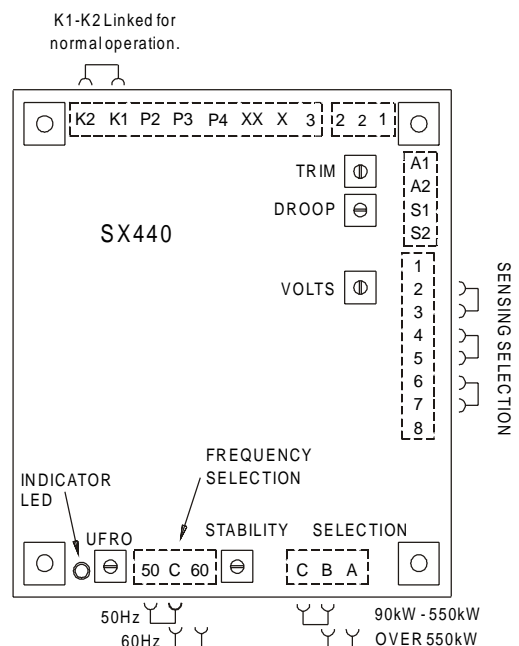

Fig. 6b

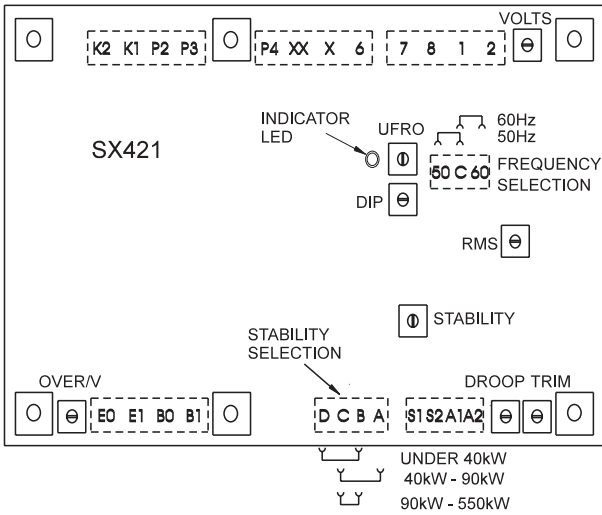

Fig. 6c

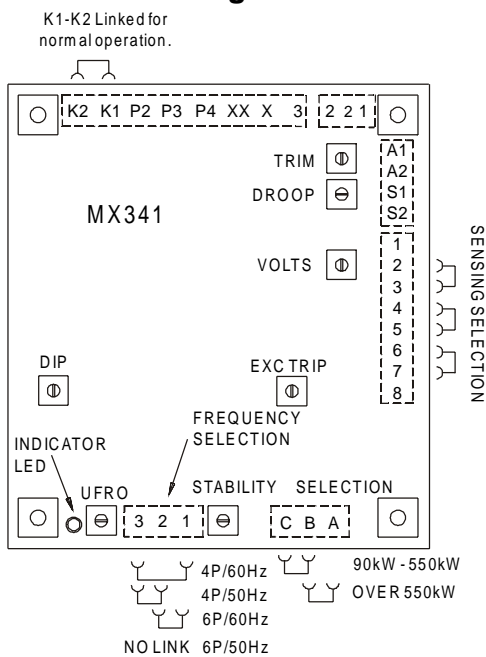

Fig. 6d

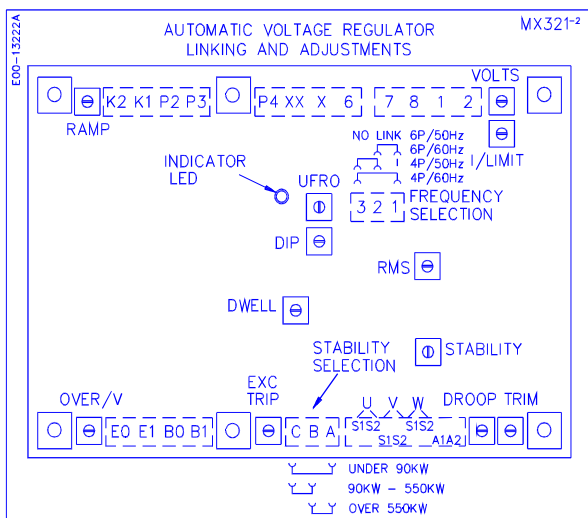



Fig. 6e

4.7 LOAD TESTING



Warning ! During testing it may be necessary to remove covers to adjust controls exposing 'live' terminals or components. Only personnel qualified to perform electrical service should carry out testing and/or adjustments. Refit all access covers after adjustments are completed.

4.7.1 AVR CONTROLLED GENERATORS - AVR ADJUSTMENTS

Refer to Fig. 6a, 6b, 6c, 6d or 6e for control potentiometer locations.

Having adjusted VOLTS and STABILITY during the initial start-up procedure, other AVR control functions should not normally need adjustment.

If however, poor voltage regulation on-load or voltage collapse is experienced, refer to the following paragraphs on each function to a) check that the symptoms observed do indicate adjustment is necessary, and b) to make the adjustment correctly.

4.7.1.1 UFRO (Under Frequency Roll Off) (AVR Types SX460, SX440, SX421, MX341 and MX321)

The AVR incorporates an underspeed protection circuit which gives a voltage/speed (Hz) characteristic as shown:

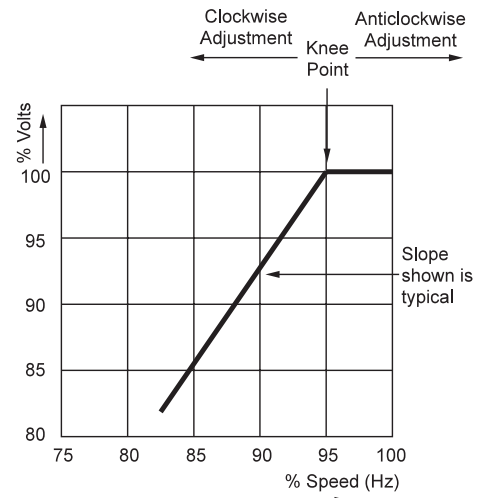

Fig. 7

The UFRO control potentiometer sets the "knee point".

Symptoms of incorrect setting are a) the light emitting diode (LED) indicator, just above the UFRO Control potentiometer, being permanently lit when the generator is on load, and b) poor voltage regulation on load, i.e. operation on the sloping part of the characteristic.

Clockwise adjustment lowers the frequency (speed) setting of the "knee point" and extinguishes the LED. For Optimum setting the LED should illuminate as the frequency falls just below nominal frequency, i.e. 47Hz on a 50Hz generator or 57Hz on a 60Hz generator.

Important ! With AVR Types MX341 and MX321. If the LED is illuminated and no output voltage is present, refer to EXC TRIP and/or OVER/V sections below.

4.7.1.2 EXC TRIP (Excitation Trip)
AVR Types MX341 and MX321

An AVR supplied from a permanent magnet generator inherently delivers maximum excitation power on a line to line or line to neutral short circuit or large overload. In order to protect the generator windings the AVR incorporates an over excitation circuit which detects high excitation and removes it after a pre-determined time, i.e. 8-10 seconds.

Symptoms of incorrect setting are the generator output collapses on load or small overload, and the LED is permanently illuminated.

The correct setting is 70 volts +/-5% between terminals X and XX.

4.7.1.3 OVER/V (Over Voltage)
AVR Type SX421, MX321

Over voltage protection circuitry is included in the AVR to remove generator excitation in the event of loss of AVR sensing input.

The MX321 has both internal electronic de-excitation and provision of a signal to operate an external circuit breaker.

The SX421 only provides a signal to operate an external breaker, which MUST be fitted if over voltage protection is required.

Incorrect setting would cause the generator output voltage to collapse at no-load or on removal of load, and the LED to be illuminated.

The correct setting is 300 volts +/-5% across terminals E1, E0. Clockwise adjustment of the OVER/V control potentiometer will increase the voltage at which the circuit operates.

4.7.1.4 TRANSIENT LOAD SWITCHING ADJUSTMENTS
AVR Types SX421, MX341 and MX321

The additional function controls of DIP and DWELL are provided to enable the load acceptance capability of the generating set to be optimised. The overall generating set performance depends upon the engine capability and governor response, in conjunction with the generator characteristics.

It is not possible to adjust the level of voltage dip or recovery independently from the engine performance, and there will always be a 'trade off' between frequency dip and voltage dip.

DIP
AVR Types SX421, MX341 and MX321

AVR Types SX421, MX341 and MX321
 The dip function control potentiometer adjusts the slope of the voltage/speed (Hz) characteristic below the knee point as shown below:

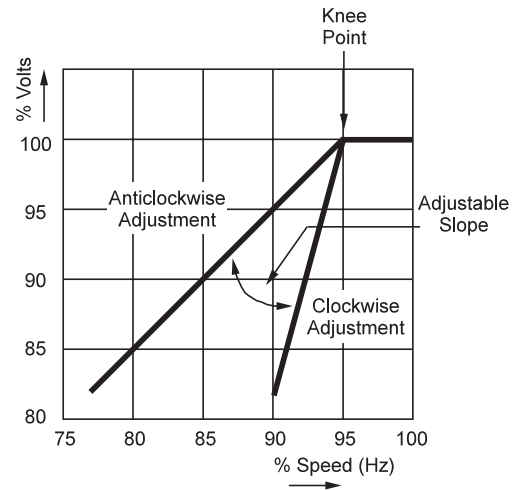

Fig. 8

DWELL
AVR Type MX321

The dwell function introduces a time delay between the recovery of voltage and recovery of speed.

The purpose of the time delay is to reduce the generator kW below the available engine kW during the recovery period, thus allowing an improved speed recovery.

Again this control is only functional below the "knee point", i.e. if the speed stays above the knee point during load switching there is no effect from the DWELL function setting.

Clockwise adjustment gives increased recovery time.

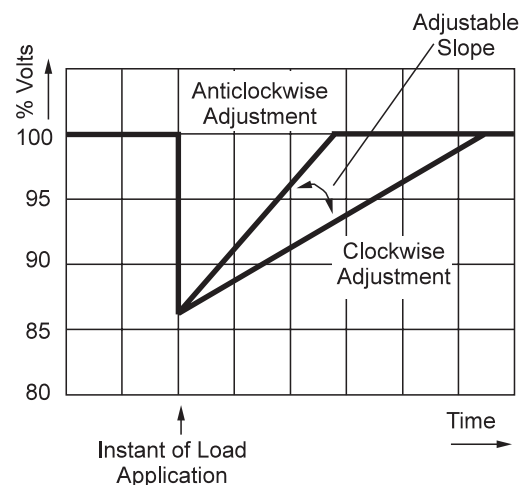

Fig. 9

The graphs shown above are representations only, since it is impossible to show the combined effects of voltage regulator and engine governor performance.

4.7.1.5 RAMP AVR Type MX321

The RAMP potentiometer enables adjustment of the time taken for the generator's initial build up to normal rated voltage during each start and run up to speed. The potentiometer is factory set to give a ramp time of three seconds, which is considered to be suitable for most applications. This time can be reduced to one second by turning the pot. fully counter clockwise, and increased to eight seconds by turning the pot. fully clockwise.

4.7.2 TRANSFORMER CONTROLLED GENERATORS - TRANSFORMER ADJUSTMENT

Normally no adjustment is required but should the no-load voltage and/or on-load voltage be unacceptable, adjustment of the transformer air gap can be made as follows.

Stop the generator. Remove transformer cover box. (Normally left hand side of the terminal box when viewed from the non drive end).

Slacken the three transformer mounting bolts along the top of the transformer.

Start the set with a voltmeter connected across the main output terminals.

Adjust the air gap between the transformer top lamination section and the transformer limbs to obtain required voltage on no-load. Slightly tighten the three mounting bolts. Switch load 'on' and 'off' two or three times. Application of load will normally raise the voltage setting slightly. With the load 'off' recheck the no-load voltage.

Readjust air gap and finally tighten mounting bolts.

Refit the access cover.

 Warning !	Failure to refit covers can result in operator personal injury or death.
---	---

4.8 ACCESSORIES

Refer to the "ACCESSORIES" - Section 6 of this Manual for setting up procedures related to generator mounted accessories.

If there are accessories for control panel mounting supplied with the generator refer to the specific accessory fitting procedures inserted inside the back cover of this book.

SECTION 5

INSTALLATION - PART 2

5.1 GENERAL

The extent of site installation will depend upon the generating set build, e.g. if the generator is installed in a canopied set with integral switchboards and circuit breaker, on site installation will be limited to connecting up the site load to the generating set output terminals. In this case reference should be made to the generating set manufacturer's instruction book and any pertinent local regulations.

If the generator has been installed on a set without switchboard or circuit breaker the following points relating to connecting up the generator should be noted.

5.2 GLANDING

The terminal box is most conveniently glanded on either the right or left hand side. Both panels are removable for drilling/punching to suit glands/or glanding boxes. If single core cables are taken through the terminal box side panel an insulated or non-magnetic gland plate should be fitted.

Incoming cables should be supported from either below or above the box level and at a sufficient distance from the centre line of the generating set so as to avoid a tight radius at the point of entry into the terminal box panel, and allow movement of the generator set on its anti-vibration mountings without excessive stress on the cable.

Before making final connections, test the insulation resistance of the windings. The AVR should be disconnected during this test.

A 500V Megger or similar instrument should be used. Should the insulation resistance be less than $5M\Omega$ the windings must be dried out as detailed in the Service and Maintenance section of this manual.

When making connections to the terminals the incoming cable termination should be placed on top of the winding lead termination(s) and clamped with the nut provided.

Important ! To avoid the possibility of swarf entering any electrical components in the terminal box, panels must be removed for drilling.

5.3 EARTHING

The neutral of the generator is not bonded to the generator frame as supplied from the factory. An earth terminal is provided inside the terminal box adjacent to the main terminals. Should it be required to operate with the neutral earthed a substantial earth conductor (normally equivalent to one half of the section of the line conductors) must be connected between the neutral and the earth terminal inside the terminal box. Additional earth terminals are provided on the generator feet. These should be already bonded to the generating set bedplate by the generating set builder, but will normally be required to be connected to the site earth system.

Caution ! Reference to local electricity regulations or safety rules should be made to ensure correct earthing procedures have been followed.

5.4 PROTECTION

It is the responsibility of the end user and his contractors/sub-contractors to ensure that the overall system protection meets the needs of any inspectorate, local electricity authority or safety rules, pertaining to the site location.

To enable the system designer to achieve the necessary protection and/or discrimination, fault current curves are available on request from the factory, together with generator reactance values to enable fault current calculations to be made.



Warning !

Incorrect installation and/or protective systems can result in personal injury and/or equipment damage. Installers must be qualified to perform electrical installation work.

5.5 COMMISSIONING

Ensure that all external cabling is correct and that all the generating set manufacturer's pre-running checks have been carried out before starting the set.

The generator AVR controls will have been adjusted during the generating set manufacturer's tests and should normally not require further adjustment.

Should malfunction occur during commissioning refer to Service and Maintenance section 'Fault Finding' procedure (subsection 7.4).

SECTION 6

ACCESSORIES

Generator control accessories may be fitted, as an option, in the generator terminal box. If fitted at the time of supply, the wiring diagram(s) in the back of this book shows the connections. When the options are supplied separately, fitting instructions are provided with the accessory.

The following matrix indicates availability of accessories with the differing AVRs.

Note the SX460 is not suitable for operation with accessories.

AVR Model	Parallel-ing Droop or Astatic	Manual Voltage Regulator	VAr/PF Control	Current Limit
SX440	✓	✗	✓	✗
SX421	✓	✗	✓	✗
MX341	✓	✓	✓	✗
MX321	✓	✓	✓	✓

6.1 REMOTE VOLTAGE ADJUST (ALL AVR TYPES)

A remote voltage adjust (hand trimmer) can be fitted.

- | | |
|---------------------------------|---|
| SX460 | Remove link 1-2 on the AVR and connect adjuster to terminals 1 and 2. |
| SX440, SX421
MX341 and MX321 | Remove link 1-2 at the auxiliary terminals and connect adjuster to terminals 1 and 2. |

6.2 PARALLEL OPERATION

Understanding of the following notes on parallel operation is useful before attempting the fitting or setting of the droop kit accessory. When operating in parallel with other generators or the mains, it is essential that the phase sequence of the incoming generator matches that of the busbar and also that all of the following conditions are met before the circuit breaker of the incoming generator is closed on to the busbar (or operational generator).

- Frequency must match within close limits.
- Voltages must match within close limits.
- Phase angle of voltages must match within close limits. A variety of techniques, varying from simple synchronising lamps to fully automatic synchronisers, can be used to ensure these conditions are met.

Important ! Failure to meet conditions 1, 2, and 3 when closing the circuit breaker, will generate excessive mechanical and electrical stresses, resulting in equipment damage.

Once connected in parallel a minimum instrumentation level per generator of voltmeter, ammeter, wattmeter (measuring total power per generator), and frequency meter is required in order to adjust the engine and generator controls to share kW in relation to engine ratings and kVAr in relation to generator ratings.

It is important to recognise that:

- True kW are derived from the engine, and speed governor characteristics determine the kW sharing between sets
and
- kVAr are derived from the generator, and excitation control characteristics determine the kVAr sharing. Reference should be made to the generating set manufacturer's instructions for setting the governor controls.

6.2.1 DROOP

The most commonly used method of kVAr sharing is to create a generator voltage characteristic which falls with decreasing power factor (increasing kVAr). This is achieved with a current transformer (C.T.) which provides a signal dependent on current phase angle (i.e. power factor) to the AVR.

The current transformer has a burden resistor on the AVR board, and a percentage of the burden resistor voltage is summed into the AVR circuit. Increasing droop is obtained by turning the DROOP control potentiometer clockwise.

The diagrams below indicate the effect of droop in a simple two generator system:-

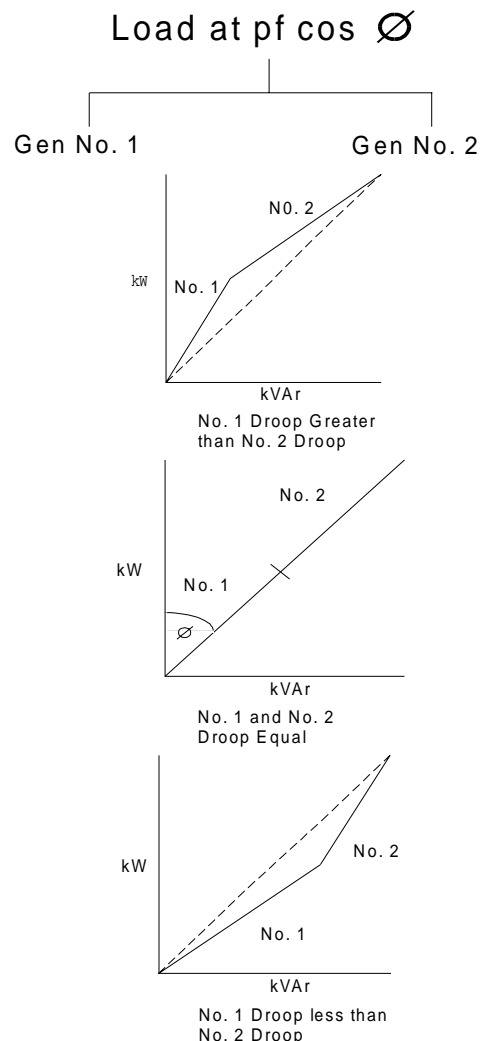

Generally 5% droop at full load current zero p.f. is sufficient to ensure kVAr sharing.

If the droop accessory has been supplied with the generator it will have been tested to ensure correct polarity and set to a nominal level of droop. The final level of droop will be set during generating set commissioning.

The following setting procedure will be found to be helpful.

6.2.1.1 SETTING PROCEDURE

Depending upon available load the following settings should be used - all are based on rated current level.

0.8 P.F. LOAD (at full load current) SET DROOP TO 3%
Zero P.F. LOAD (at full load current) SET DROOP TO 5%

Setting the droop with low power factor load is the most accurate. Run each generator as a single unit at rated frequency or rated frequency + 4% depending upon type of governor and nominal voltage. Apply available load to rated current of the generator. Adjust 'DROOP' control potentiometer to give droop in line with above table. Clockwise rotation increases amount of droop. Refer to Fig 9a, 9b, 9c or 9d for potentiometer locations.

Note 1)

Reverse polarity of the C.T. will raise the generator voltage with load. The polarities S1-S2 shown on the wiring diagrams are correct for clockwise rotation of the generator looking at the drive end. Reversed rotation requires S1-S2 to be reversed.

Note 2)

The most important aspect is to set all generators equal. The precise level of droop is less critical.

Note 3)

A generator operated as a single unit with a droop circuit set at rated load 0.8 power factor is unable to maintain the usual +/- 0.5% regulation. A shorting switch can be connected across S1-S2 to restore regulation for single running.

Important ! **LOSS OF FUEL to an engine can cause its generator to motor with consequent damage to the generator windings. Reverse power relays should be fitted to trip main circuit breaker. LOSS OF EXCITATION to the generator can result in large current oscillations with consequent damage to generator windings. Excitation loss detection equipment should be fitted on trip main circuit breaker.**

6.2.2 ASTATIC CONTROL

The 'droop' current transformer can be used in a connection arrangement which enables the normal regulation of the generator to be maintained when operating in parallel.

This feature is only supplied from the factory as a fitted droop kit, however, if requested at the time of order, the diagrams inside the back cover of this book will give the necessary site connections. The end user is required to provide a shorting switch for the droop current transformer secondary.

Should the generator be required to be converted from standard droop to 'astatic' control, diagrams are available on request.

The setting procedure is exactly the same as for DROOP. (Subsection 6.2.1.1)

Important ! **When using this connection arrangement a shorting switch is required across each C.T. burden (terminals S1 and S2.)The switch must be closed a) when a generating set is not running and b) when a generating set is selected for single running.**

6.3 MANUAL VOLTAGE REGULATOR (MVR) - MX341 and MX321 AVR

This accessory is provided as an 'emergency' excitation system, in the event of an AVR failure.

Powered from the PMG output the unit is manually set, but automatically controls the excitation current, independent of generator voltage or frequency.

The unit is provided with 'MANUAL', 'OFF', 'AUTO' switching facility.

'MANUAL'

- position connects the exciter field to the MVR output. Generator output is then controlled by the operator adjusting the excitation current.

'OFF'

- disconnects the exciter field from both MVR and the normal AVR.

'AUTO'

- connects the exciter field to the normal AVR and the generator output is controlled at the pre-set voltage under AVR control.

Switching mode of operation should be carried out with the generator set stationary to avoid voltage surges on the connected load, although neither the MVR nor AVR will be damaged should the switching be carried out with the set running.

6.4 OVERVOLTAGE DE-EXCITATION BREAKER SX421 and MX321 AVR

This accessory provides positive interruption of the excitation power in the event of overvoltage due to loss of sensing or internal AVR faults including the output power device.

With the MX321 AVR this accessory is supplied loose for fitting in the control panel.

In the case of the SX421 the circuit breaker is always supplied and will normally be fitted in the generator.

Important ! **When the circuit breaker is supplied loose, the AVR is fitted with a link on terminals K1-K2 to enable operation of the AVR. When connecting the circuit breaker this link must be removed.**

6.4.1 RESETTING THE BREAKER

In the event of operation of the circuit breaker, indicated by loss of generator output voltage, manual resetting is required. When in the "tripped" state the circuit breaker switch lever shows "OFF". To reset move the switch lever to the position showing "ON".

When fitted in the generator, access to the breaker is gained by removal of the AVR access cover.



Terminals which are LIVE with the generating set running are exposed when the AVR access cover is removed. Resetting of the circuit breaker MUST be carried out with the generating set stationary, and engine starting circuits disabled.

The circuit breaker is mounted on the AVR mounting bracket either to the left or to the right of the AVR depending upon AVR position. After resetting the circuit breaker replace the AVR access cover before restarting the generating set. Should resetting of the circuit breaker not restore the generator to normal operation, refer to subsection 7.5.

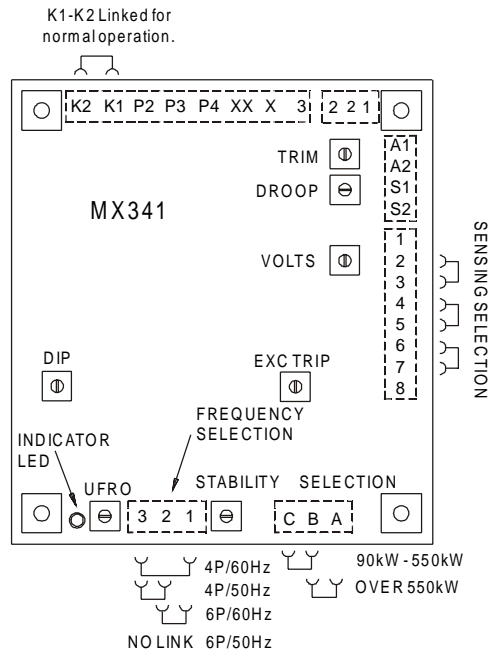

Fig. 9c

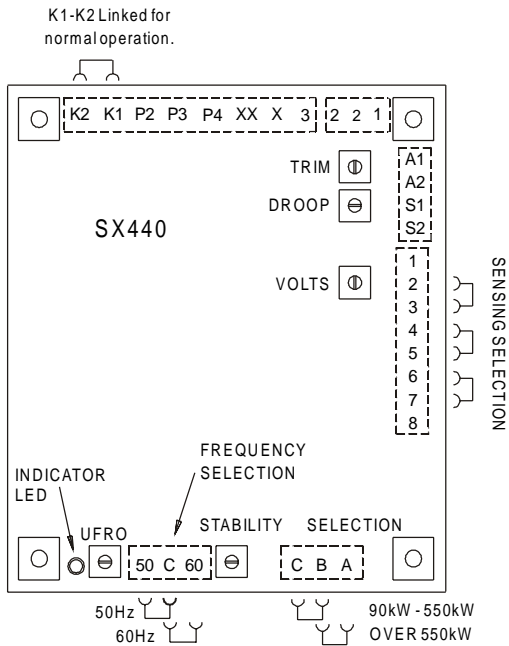

Fig. 9a

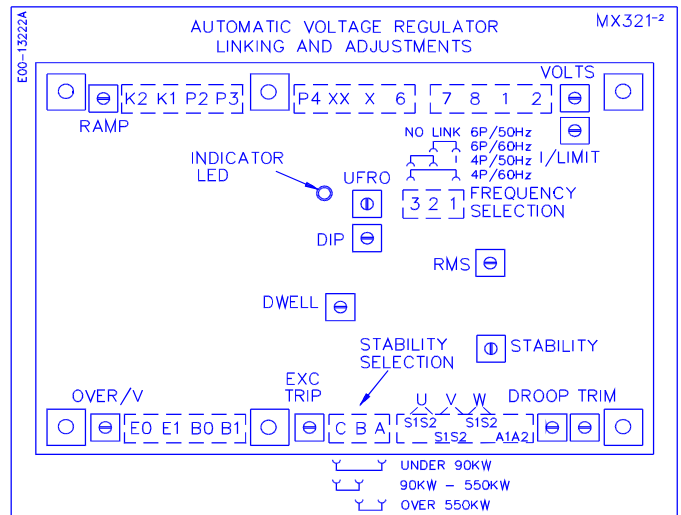

Fig. 9d

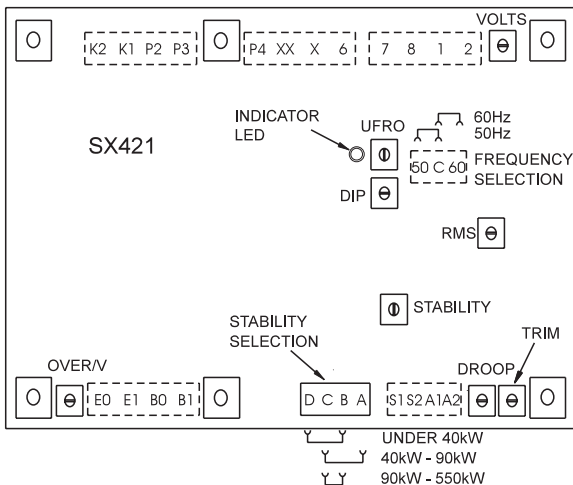

Fig. 9b

6.5 CURRENT LIMIT - MX321 AVR

These accessories work in conjunction with the AVR circuits to provide an adjustment to the level of current delivered into a fault. One current transformer (CT) per phase is fitted to provide current limiting on any line to line or line to neutral fault.

Note: The W phase CT can also provide "DROOP". Refer to 6.2.1.1 for setting droop independent of current limit.

Adjustment means is provided with the "I/LIMIT" control potentiometer on the AVR. Refer to Fig. 9d for location. If current limit transformers are supplied with the generator the limit will be set in accordance with the level specified at the time of order, and no further adjustment will be necessary. However, should the level need to be adjusted, refer to the setting procedure given in 6.5.1.

6.5.1 SETTING PROCEDURE

Run the generating set on no-load and check that engine governor is set to control nominal speed.

Stop the generating set. Remove the link between terminals K1-K2 at the auxiliary terminal block and connect a 5A switch across the terminals K1-K2.

Turn the "I/LIMIT" control potentiometer fully anticlockwise. Short circuit the stator winding with a bolted 3 phase short at the main terminals. An AC current clip-on ammeter is required to measure the winding lead current.

With the switch across K1-K2 open start the generating set.

Close the switch across K1-K2 and turn the "I/LIMIT" control potentiometer clockwise until required current level is observed on the clip-on ammeter. As soon as correct setting is achieved open the K1-K2 switch.

Should the current collapse during the setting procedure, the internal protective circuits of the AVR will have operated. In this event shut down the set and open the K1-K2 switch. Restart the set and run for 10 minutes with K1-K2 switch open, to cool the generator windings, before attempting to resume the setting procedure.

Important ! Failure to carry out the correct COOLING procedure, may cause overheating and consequent damage to the generator windings.

6.6 POWER FACTOR CONTROLLER (PFC3)

This accessory is primarily designed for those generator applications where operation in parallel with the mains supply is required.

Protection against loss of mains voltage or generator excitation is not included in the unit and the system designer must incorporate suitable protection.

The electronic control unit requires both droop and kVAr current transformers. When supplied with the generator, wiring diagrams inside the back cover of this manual show the connections and the additional instruction leaflet provided gives details of setting procedures for the power factor controller (PFC3).

The unit monitors the power factor of the generator current and adjusts excitation to maintain the power factor constant.

This mode can also be used to control the power factor of the mains if the point of current monitoring is moved to the mains cables. Refer to the factory for appropriate details.

It is also possible to operate the unit to control kVAr of the generator if required. Refer to the factory for appropriate details.

SECTION 7

SERVICE AND MAINTENANCE

As part of routine maintenance procedures, periodic attention to winding condition (particularly when generators have been idle for a long period) and bearings is recommended. (Refer to subsections 7.1 and 7.2 respectively).

When generators are fitted with air filters regular inspection and filter maintenance is required. (Refer to subsection 7.3).

7.1 WINDING CONDITION



Warning !

Service and fault finding procedures present hazards which can result in severe personal injury or death. Only personnel qualified to perform electrical and mechanical service should carry out these procedures. Ensure engine starting circuits are disabled before commencing service or maintenance procedures. Isolate any anti-condensation heater supply.

Guidance of Typical Insulation Resistance [IR] Values

The following is offered as general information about IR values and is aimed at providing guidance about the typical IR values for generators from new through to the point of refurbishment.

New Machines

The generators Insulation Resistance, along with many other critical factors, will have been measured during the alternator manufacturing process. The generator will have been transported with an appropriate packaging suitable for the method of delivery to the Generating Set assemblers works. Where we expect it to be stored in a suitable location protected from adverse environmental conditions.

However, absolute assurance that the generator will arrive at the Gen-set production line with IR values still at the factory test levels of above 100 M Ω cannot be guaranteed.

At Generating Set Manufacturers Works

The generator should have been transported and stored such that it will be delivered to the assembly area in a clean dry condition. If held in appropriate storage conditions the generator IR value should typically be 25 M Ω .

If the unused/new generators IR values fall below 10 M Ω then a drying out procedure should be implemented by one of the processes outlined below before being despatched to the end customer's site. Some investigation should be undertaken into the storage conditions of the generator while on site.

Generators in Service

Whilst It is known that a generator will give reliable service with an IR value of just 1.0 M Ω . For a relatively new generator to be so low it must have been subjected to inappropriate operating or storage conditions.

Any temporarily reduction in IR values can be restored to expected values by following one of the drying out procedures.

7.1.1 WINDING CONDITION ASSESSMENT

Caution ! The AVR should be disconnected and the Resistance Temperature Detector (R.T.D.) leads grounded during this test.

The condition of the windings can be assessed by measurement of insulation resistance [IR] between phase to phase, and phase to earth.

Measurement of winding insulation should be carried out: -

1. As part of a periodic maintenance plan.
2. After prolonged periods of shutdown.
3. When low insulation is suspected, e.g. damp or wet windings.

Care should be taken when dealing with windings that are suspected of being excessively damp or dirty. The initial measurement of the [IR] Insulation Resistance should be established using a low voltage (500V) megger type instrument. If manually powered the handle should initially be turned slowly so that the full test voltage will not be applied, and only applied for long enough to very quickly assess the situation if low values are suspected or immediately indicated.

Full megger tests or any other form of high voltage test should not be applied until the windings have been dried out and if necessary cleaned.

Procedure for Insulation Testing

Disconnect all electronic components, AVR, electronic protection equipment etc. Ground the [RTD's] Resistance Temperature Detection devices if fitted. Short out the diodes on the rotating diode assembly. Be aware of all components connected to the system under test that could cause false readings or be damaged by the test voltage.

Carry out the insulation test in accordance with the 'operating instructions for the test equipment.

The measured value of insulation resistance for all windings to earth and phase to phase should be compared with the guidance given above for the various 'life stages' of a generator. The minimum acceptable value must be greater than 1.0 M Ω .

If low winding insulation is confirmed use one or more of the methods, given below, for drying the winding should be carried out.

7.1.2 METHODS OF DRYING OUT GENERATORS

Cold Run

Consider a good condition generator that has not been run for some time, and has been standing in damp, humid conditions. It is possible that simply running the gen set unexcited - AVR terminals K1 K2 open circuit - for a period of say 10 minutes will sufficiently dry the surface of the windings and raise the IR sufficiently, to greater than 1.0 M Ω , and so allow the unit to be put into service.

Blown Air Drying

Remove the covers from all apertures to allow the escape of the water-laden air. During drying, air must be able to flow freely through the generator in order to carry off the moisture.

Direct hot air from two electrical fan heaters of around 1 – 3 kW into the generator air inlet apertures. Ensure the heat source is at least 300mm away from the windings to avoid over heating and damage to the insulation.

Apply the heat and plot the insulation value at half hourly intervals. The process is complete when the parameters covered in the section entitled, 'Typical Drying Out Curve', are met.

Remove the heaters, replace all covers and re-commission as appropriate.

If the set is not to be run immediately ensure that the anti-condensation heaters are energised, and retest prior to running.

Short Circuit Method

NOTE: This process should only be performed by a competent engineer familiar with safe operating practices within and around generator sets of the type in question.

Ensure the generator is safe to work on, initiate all mechanical and electrical safety procedures pertaining to the genset and the site.

Bolt a short circuit of adequate current carrying capacity, across the main terminals of the generator. The shorting link should be capable of taking full load current.

Disconnect the cables from terminals "X" and "XX" of the AVR.

Connect a variable dc supply to the "X" (positive) and "XX" (negative) field cables. The dc supply must be able to provide a current up to 2.0 Amp at 0 - 24 Volts.

Position a suitable ac ammeter to measure the shorting link current.

Set the dc supply voltage to zero and start the generating set. Slowly increase the dc voltage to pass current through the exciter field winding. As the excitation current increases, so the stator current in the shorting link will increase. This stator output current level must be monitored, and not allowed to exceed 80% of the generators rated output current.

After every 30 minutes of this exercise:

Stop the generator and switch off the separate excitation supply, and measure and record the stator winding IR values, and plot the results. The resulting graph should be compared with the classic shaped graph. This drying out procedure is complete when the parameters covered in the section entitled 'Typical Drying Out Curve' are met.

Once the Insulation Resistance is raised to an acceptable level - minimum value 1.0 MΩ – the dc supply may be removed and the exciter field leads "X" and "XX" re-connected to their terminals on the AVR.

Rebuild the genset, replace all covers and re-commission as appropriate.

If the set is not to be run immediately ensure that the anti-condensation heaters are energised, and retest the generator prior to running.

TYPICAL DRYING OUT CURVE

Whichever method is used to dry out the generator the resistance should be measured every half-hour and a curve plotted as shown. (fig 6.)

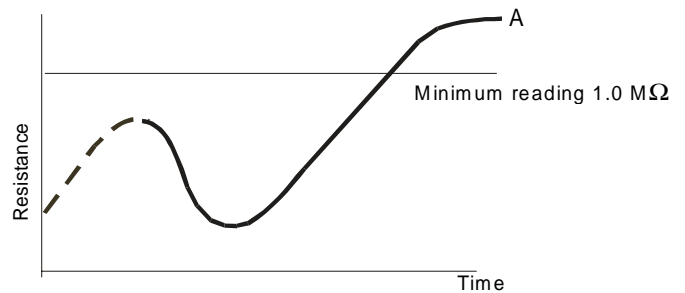

Fig. 9

The illustration shows a typical curve for a machine that has absorbed a considerable amount of moisture. The curve indicates a temporary increase in resistance, a fall and then a gradual rise to a steady state. Point 'A', the steady state, must be greater than 1.0 MΩ. (If the windings are only slightly damp the dotted portion of the curve may not appear).

For general guidance expect that the typical time to reach point 'A' will be:

- 1 hour for a BC16/18,
- 2 hours for a UC22/27
- 3 hours for an HC4,5,6&7

Drying should be continued after point "A" has been reached for at least one hour.

It should be noted that as winding temperature increases, values of insulation resistance may significantly reduce. Therefore, the reference values for insulation resistance can only be established with windings at a temperature of approximately 20°C.

If the IR value remains below 1.0 MΩ, even after the above drying methods have been properly conducted, then a Polarisation Index test [PI] should be carried out.

If the minimum value of 1.0 MΩ for all components cannot be achieved rewinding or refurbishment of the generator will be necessary.

The generator must not be put into service until the minimum values can be achieved.

Important ! The short circuit must not be applied with the AVR connected in circuit. Current in excess of the rated generator current will cause damage to the windings.

After drying out, the insulation resistances should be rechecked to verify minimum resistances quoted above are achieved. On re-testing it is recommended that the main stator insulation resistance is checked as follows:-
Separate the neutral leads

Ground	V and W	phase and megger	U phase to ground
Ground	U and W	phase and megger	V phase to ground
Ground	U and V	phase and megger	W phase to ground

If the minimum value of 1.0MΩ is not obtained, drying out must be continued and the test repeated.

7.2 BEARINGS

All bearings are supplied sealed for life and are, therefore, not regreasable.

Important ! The life of a bearing in service is subject to the working conditions and the environment.

Important ! Long stationary periods in an environment where there is vibration can cause false brinnelling which puts flats on the ball and grooves on the races.
Very humid atmospheres or wet conditions can emulsify the grease and cause corrosion.

Important ! High axial vibration from the engine or misalignment of the set will stress the bearing.

The bearing, in service, is affected by a variety of factors that together will determine the bearing life. We recommend that the health of the bearings be monitored, using 'spike energy' vibration monitoring equipment. This will allow the timely replacement of bearings, that exhibit a deteriorating trend, during a major engine overhaul.

If excessive heat, noise or vibration is detected, change the bearing as soon as practicable. Failure to do so could result in bearing failure.

In the event that 'spike energy' vibration monitoring equipment is not available, it is strongly recommend that consideration be given to changing the bearing during each 'major engine overhaul'.

Belt driven application will impose an additional load on bearings. The bearing life will therefore be significantly affected. It is important that the side load limits given in SECTION 3 are not exceeded and the health of the bearing is monitored more closely.

7.3 AIR FILTERS

The frequency of filter maintenance will depend upon the severity of the site conditions. Regular inspection of the elements will be required to establish when cleaning is necessary.

7.3.1 CLEANING PROCEDURE

 <p>Danger !</p>	<p>Removal of filter elements enables access to LIVE parts. Only remove elements with the generator out of service.</p>
--	--

Remove the filter elements from the filter frames. Immerse or flush the element with a suitable detergent until the element is clean. Dry elements thoroughly before refitting.

7.4 FAULT FINDING

Important ! Before commencing any fault finding procedure examine all wiring for broken or loose connections.

Four types of excitation control system, involving four types of AVR, can be fitted to the range of generators covered by this manual. The systems can be identified by a combination of AVR type, where applicable, and the last digit of the generator frame size designation. Refer to the generator nameplate then proceed to the appropriate subsection as indicated below:-

DIGIT	EXCITATION CONTROL	SUBSECTION
6	SX460 AVR	7.4.1
4	SX440 AVR	7.4.2
4	SX421 AVR	7.4.3
5	Transformer control	7.4.4
3	MX341 AVR	7.4.5
3	MX321 AVR	7.4.6

7.4.1 SX460 AVR - FAULT FINDING

No voltage build-up when starting set	<ol style="list-style-type: none"> 1. Check speed 2. Check residual voltage. Refer to subsection 7.4.7. 3. Follow Separate Excitation Test Procedure to check generator and AVR.
Unstable voltage either on no-load or with load	<ol style="list-style-type: none"> 1. Check speed stability. 2. Check stability setting. Refer to subsection 4.6.
High voltage either on no-load or with load	<ol style="list-style-type: none"> 1. Check speed. 2. Check that generator load is not capacitive (leading power factor).
Low voltage no-load	<ol style="list-style-type: none"> 1. Check speed. 2. Check link 1-2 or external hand trimmer leads for continuity.
Low voltage on-load	<ol style="list-style-type: none"> 1. Check speed. 2. Check UFRO setting. Refer to subsection 4.7.1.1. 3. Follow Separate Excitation Procedure to check generator and AVR. Refer to subsection 7.5.

7.4.2 SX440 AVR - FAULT FINDING

No voltage build-up when starting set.	<ol style="list-style-type: none"> 1. Check link K1-K2 on auxiliary terminals. 2. Check speed. 3. Check residual voltage. Refer to subsection 7.4.7. 4. Follow Separate Excitation Test Procedure to check generator and AVR. Refer to subsection 7.5.
Unstable voltage either on no-load or with load.	<ol style="list-style-type: none"> 1. Check speed stability. 2. Check stability setting. Refer to subsection 4.6.
High voltage either on no-load or with load	<ol style="list-style-type: none"> 1. Check speed. 2. Check that generator load is not capacitive (leading power factor).
Low voltage no-load	<ol style="list-style-type: none"> 1. Check speed. 2. Check link 1-2 or external hand trimmer leads for continuity.
Low voltage on-load	<ol style="list-style-type: none"> 1. Check speed. 2. Check UFRO setting. Refer to subsection 4.7.1.1. 3. Follow Separate Excitation Procedure to check generator and AVR. Refer to subsection 7.5.

7.4.3 SX421 AVR - FAULT FINDING

No voltage build-up when starting set	<ol style="list-style-type: none"> 1. Check circuit breaker 'ON'. Refer to subsection 6.4.1. 2. Check speed. 3. Check residual voltage. Refer to subsection 7.4.7. 4. Follow Separate Excitation Procedure to check generator and AVR. Refer to subsection 7.5.
Unstable voltage either on no-load or with load	<ol style="list-style-type: none"> 1. Check speed stability. 2. Check stability setting. Refer to subsection 4.6.
High voltage either on no-load or with load	<ol style="list-style-type: none"> 1. Check speed. 2. Check link 1-2 or external hand trimmer leads for continuity. Check continuity of leads 7-8 and P3-P2 for continuity. 3. Check that generator load is not capacitive (leading power factor).
Low voltage no-load	<ol style="list-style-type: none"> 1. Check speed. 2. Check link 1-2 or external hand trimmer leads for continuity.

Low voltage on-load	<ol style="list-style-type: none"> 1. Check speed. 2. Check UFRO setting. Refer to subsection 4.7.1.1. 3. Follow Separate Excitation to check generator and AVR. Refer to subsection 7.5.
Excessive voltage/speed dip on-load switching	<ol style="list-style-type: none"> 1. Check governor response. 2. Refer to generating set manual. Check 'DIP' setting. Refer to subsection 4.7.1.4.

7.4.4 TRANSFORMER CONTROL - FAULT FINDING

No voltage build-up when starting set	<ol style="list-style-type: none"> 1. Check transformers rectifiers. 2. Check transformer secondary winding for open circuit.
Low voltage	<ol style="list-style-type: none"> 1. Check speed. 2. Check transformer air gap setting. Refer to subsection 4.7.2.
High voltage	<ol style="list-style-type: none"> 1. Check speed. 2. Check transformer air gap setting. Refer to subsection 4.7.2. 3. Check transformer secondary winding for short circuited turns.
Excessive voltage drop on-load	<ol style="list-style-type: none"> 1. Check speed drop on-load. 2. Check transformer rectifiers. Check transformer air gap setting. Refer to subsection 4.7.2.

7.4.5 MX341 AVR - FAULT FINDING

No voltage build-up when starting set	<ol style="list-style-type: none"> 1. Check link K1-K2 on auxiliary terminals. 2. Follow Separate Excitation Test Procedure to check machine and AVR. Refer to subsection 7.5.
Loss of voltage when set running	<ol style="list-style-type: none"> 1. First stop and re-start set. If no voltage or voltage collapses after short time, follow Separate Excitation Test Procedure. Refer to subsection 7.5.
Generator voltage high followed by collapse	<ol style="list-style-type: none"> 1. Check sensing leads to AVR. 2. Refer to Separate Excitation Test Procedure. Refer to subsection 7.5.
Voltage unstable either on no-load or with load	<ol style="list-style-type: none"> 1. Check speed stability. 2. Check "STAB" setting. Refer to Load Testing section for procedure. Refer to subsection 4.6.
Low voltage on-load	<ol style="list-style-type: none"> 1. Check speed. 2. If correct check "UFRO" setting. Refer to subsection 4.7.1.1.
Excessive voltage/speed dip on load switching	<ol style="list-style-type: none"> 1. Check governor response. Refer to generating set manual. Check "DIP" setting. Refer to subsection 4.7.1.4.
Sluggish recovery on load switching	<ol style="list-style-type: none"> 1. Check governor response. Refer to generating set manual.

7.4.6 MX321 AVR - FAULT FINDING

No voltage build-up when starting set	<ol style="list-style-type: none"> 1. Check link K1-K2 on auxiliary terminals. Follow Separate Excitation Test Procedure to check machine and AVR. Refer to subsection 7.5.
Voltage very slow to build up	<ol style="list-style-type: none"> 1. Check setting of ramp potentiometer. Refer to 4.7.1.5.
Loss of voltage when set running	<ol style="list-style-type: none"> 1. First stop and re-start set. If no voltage or voltage collapses after short time, follow Separate Excitation Test Procedure. Refer to subsection 7.5.
Generator voltage high followed by collapse	<ol style="list-style-type: none"> 1. Check sensing leads to AVR. 2. Refer to Separate Excitation Test Procedure. Refer to subsection 7.5.
Voltage unstable either on no-load or with load	<ol style="list-style-type: none"> 1. Check speed stability. 2. Check "STAB" setting. Refer to Load Testing section for procedure. Refer to subsection 4.6.
Low voltage on-load	<ol style="list-style-type: none"> 1. Check speed. 2. If correct check "UFRO" setting. Refer to subsection 4.7.1.1.
Excessive voltage/speed dip on load switching	<ol style="list-style-type: none"> 1. Check governor responses. Refer to generating set manual. Check "DIP" setting. Refer to subsection 4.7.1.4.
Sluggish recovery on load switching	<ol style="list-style-type: none"> 1. Check governor response. Refer to generating set manual. Check "DWELL" setting. Refer to Load Testing section 4.7.1.4.

7.4.7 RESIDUAL VOLTAGE CHECK

This procedure is applicable to generators with either SX460 or SX440 or SX421 AVR.

With the generator set stationary remove AVR access cover and leads X and XX from the AVR.

Start the set and measure voltage across AVR terminals 7-8 on SX460 AVR or P2-P3 on SX440 or SX421 AVR.

Stop the set, and replace leads X and XX on the AVR terminals. If the measured voltage was above 5V the generator should operate normally.

If the measured voltage was under 5V follow the procedure below.

Using a 12 volt d. c. battery as a supply clip leads from battery negative to AVR terminal XX, and from battery positive through a diode to AVR terminal X. See Fig. 10.

Important ! A diode must be used as shown below to ensure the AVR is not damaged.

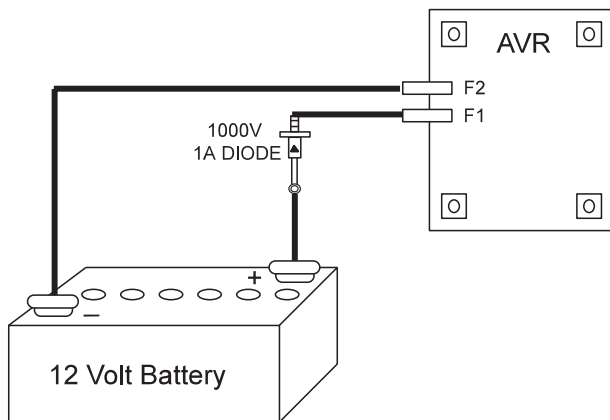

Fig. 11

Important ! If the generating set battery is used for field flashing the generator main stator neutral must be disconnected from earth.

Restart the set and note output voltage from main stator, which should be approximately nominal voltage, or voltage at AVR terminals 7 and 8 on SX460, P2-P3 on SX440 or SX421 which should be between 170 and 250 volts.

Stop the set and unclip battery supply from terminals X and XX. Restart the set. The generator should now operate normally. If no voltage build-up is obtained it can be assumed a fault exists in either the generator or the AVR circuits. Follow the SEPARATE EXCITATION TEST PROCEDURE to check generator windings, rotating diodes and AVR. Refer to subsection 7.5.

7.5 SEPARATE EXCITATION TEST PROCEDURE

The generator windings, diode assembly and AVR can be checked using the appropriate following section.

7.5.1 GENERATOR WINDINGS, ROTATING DIODES and PERMANENT MAGNET GENERATOR (PMG)

7.5.2 EXCITATION CONTROL TEST.

7.5.1 GENERATOR WINDINGS, ROTATING DIODES and PERMANENT MAGNET GENERATOR (PMG)

Important ! The resistances quoted apply to a standard winding. For generators having windings or voltages other than those specified refer to factory for details. Ensure all disconnected leads are isolated and free from earth.

Important ! Incorrect speed setting will give proportional error in voltage output.

CHECKING PMG

Start the set and run at rated speed.

Measure the voltages at the AVR terminals P2, P3 and P4. These should be balanced and within the following ranges:-

50Hz generators - 170-180 volts
60Hz generators - 200-216 volts

Should the voltages be unbalanced stop the set, remove the PMG sheet metal cover from the non drive end bracket and disconnect the multipin plug in the PMG output leads. Check leads P2, P3, P4 for continuity. Check the PMG stator resistances between output leads. These should be balanced and within +/-10% of 2.3 ohms. If resistances are unbalanced and/or incorrect the PMG stator must be replaced. If the voltages are balanced but low and the PMG stator winding resistances are correct - the PMG rotor must be replaced.

CHECKING GENERATOR WINDINGS AND ROTATING DIODES

This procedure is carried out with leads X and XX disconnected at the AVR or transformer control rectifier bridge and using a 12 volt d.c. supply to leads X and XX.

Start the set and run at rated speed.

Measure the voltages at the main output terminals U, V and W. If voltages are balanced and within +/-10% of the generator nominal voltage, refer to 7.5.1.1.

Check voltages at AVR terminals 6, 7 and 8. These should be balanced and between 170-250 volts.

If voltages at main terminals are balanced but voltage at 6, 7 and 8 are unbalanced, check continuity of leads 6, 7 and 8. Where an isolating transformer is fitted (MX321 AVR) check transformer windings. If faulty the transformer unit must be replaced.

If voltages are unbalanced, refer to 7.5.1.2.

7.5.1.1 BALANCED MAIN TERMINAL VOLTAGES

If all voltages are balanced within 1% at the main terminals, it can be assumed that all exciter windings, main windings and main rotating diodes are in good order, and the fault is in the AVR or transformer control. Refer to subsection 7.5.2 for test procedure.

If voltages are balanced but low, there is a fault in the main excitation windings or rotating diode assembly. Proceed as follows to identify:-

Rectifier Diodes

The diodes on the main rectifier assembly can be checked with a multimeter. The flexible leads connected to each diode should be disconnected at the terminal end, and the forward and reverse resistance checked. A healthy diode will indicate a very high resistance (infinity) in the reverse direction, and a low resistance in the forward direction. A faulty diode will give a full deflection reading in both directions with the test meter on the 10,000 ohms scale, or an infinity reading in both directions.

On an electronic digital meter a healthy diode will give a low reading in one direction, and a high reading in the other.

Replacement of Faulty Diodes

The rectifier assembly is split into two plates, the positive and negative, and the main rotor is connected across these plates. Each plate carries 3 diodes, the negative plate carrying negative biased diodes and the positive plate carrying positive biased diodes. Care must be taken to ensure that the correct polarity diodes are fitted to each respective plate. When fitting the diodes to the plates they must be tight enough to ensure a good mechanical and electrical contact, but should not be overtightened. The recommended torque tightening is 4.06 - 4.74Nm (36-42lb in).

Surge Suppressor

The surge suppressor is a metal-oxide varistor connected across the two rectifier plates to prevent high transient reverse voltages in the field winding from damaging the diodes. This device is not polarised and will show a virtually infinite reading in both directions with an ordinary resistance meter. If defective this will be visible by inspection, since it will normally fail to short circuit and show signs of disintegration. Replace if faulty.

Main Excitation Windings

If after establishing and correcting any fault on the rectifier assembly the output is still low when separately excited, then the main rotor, exciter stator and exciter rotor winding resistances should be checked (see Resistance Charts), as the fault must be in one of these windings. The exciter stator resistance is measured across leads X and XX. The exciter rotor is connected to six studs which also carry the diode lead terminals. The main rotor winding is connected across the two rectifier plates. The respective leads must be disconnected before taking the readings.

Resistance values should be within +/-10% of the values given in the table below:-

Frame Size	Main Rotor	Exciter Stator			Exciter Rotor
		Type 1	Type 2*	Type 3**	
UC22C	0.59	21	28	138	0.142
UC22D	0.64	21	28	138	0.142
UC22E	0.69	20	30	155	0.156
UC22F	0.83	20	30	155	0.156
UC22G	0.94	20	30	155	0.156
UC27C	1.12	20	-	-	0.156
UC27D	1.26	20	-	-	0.156
UC27E	1.34	20	-	-	0.182
UC27F	1.52	20	-	-	0.182
UC27G	1.69	20	-	-	0.182
UC27H	1.82	20	-	-	0.182
UCD27J	2.08	20	-	-	0.182
UCD27K	2.08	20	-	-	0.182

* Used with 1 phase transformer controlled 3 phase or 1 phase generators.

** Used with 3 phase transformer controlled 3 phase generators.

7.5.1.2 UNBALANCED MAIN TERMINAL VOLTAGES

If voltages are unbalanced, this indicates a fault on the main stator winding or main cables to the circuit breaker. NOTE: Faults on the stator winding or cables may also cause noticeable load increase on the engine when excitation is applied. Disconnect the main cables and separate the winding leads U1-U2, U5-U6, V1-V2, V5-V6, W1-W2, W5-W6 to isolate each winding section. (U1-L1, U2-L4 on single phase generators).

Measure each section resistance - values should be balanced and within +/-10% of the value given below:-

AVR CONTROLLED GENERATORS				
Frame Size	SECTION RESISTANCES			
	Winding 311	Winding 17	Winding 05	Winding 06
UC22C	0.09	0.14	0.045	0.03
UC22D	0.065	0.1	0.033	0.025
UC22E	0.05	0.075	0.028	0.02
UC22F	0.033	0.051	0.018	0.012
UC22G	0.028	0.043	0.014	0.01
UC27C	0.03	0.044	0.016	0.011
UC27D	0.019	0.026	0.01	0.007
UC27E	0.016	0.025	0.009	0.008
UC27F	0.012	0.019	0.007	0.005
UC27G	0.01	0.013	0.006	0.004
UC27H	0.008	0.014	0.004	0.004
UCD27J	0.006	0.009	-	-
UCD27K	0.006	0.009	-	-

TRANSFORMER CONTROLLED GENERATORS					
Frame Size	SECTION RESISTANCES, 3 PHASE WINDINGS				
	380V	400V	415V	416V	460V
	50Hz	50Hz	50Hz	60Hz	60Hz
UC22C	0.059	0.078	0.082	0.055	0.059
UC22D	0.054	0.056	0.057	0.049	0.054
UC22E	0.041	0.05	0.053	0.038	0.041
UC22F	0.031	0.032	0.033	0.025	0.031
UC22G	0.022	0.026	0.028	0.021	0.022

Measure insulation resistance between sections and each section to earth.

Unbalanced or incorrect winding resistances and/or low insulation resistances to earth indicate rewinding of the stator will be necessary. Refer to removal and replacement of component assemblies subsection 7.5.3.

7.5.2 EXCITATION CONTROL TEST

7.5.2.1 AVR FUNCTION TEST

All types of AVR's can be tested with this procedure:

1. Remove exciter field leads X & XX (F1 & F2) from the AVR terminals X & XX (F1 & F2).
2. Connect a 60W 240V household lamp to AVR terminals X & XX (F1 & F2).
3. Set the AVR VOLTS control potentiometer fully clockwise.
4. Connect a 12V, 1.0A DC supply to the exciter field leads X & XX (F1 & F2) with X (F1) to the positive.

5. Start the generating set and run at rated speed.
6. Check that the generator output voltage is within +/-10% of rated voltage.

Voltages at AVR terminals 7-8 on SX460 AVR or P2-P3 on SX440 or SX421 AVR should be between 170 and 250 volts. If the generator output voltage is correct but the voltage on 7-8 (or P2-P3) is low, check auxiliary leads and connections to main terminals.

Voltages at P2, P3, P4 terminals on MX341 and MX321 should be as given in 7.5.1.

The lamp connected across X-XX should glow. In the case of the SX460, SX440 and SX421 AVRs the lamp should glow continuously. In the case of the MX341 and MX321 AVRs the lamp should glow for approximately 8 secs. and then turn off. Failure to turn off indicates faulty protection circuit and the AVR should be replaced. Turning the "VOLTS" control potentiometer fully anti-clockwise should turn off the lamp with all AVR types.

Should the lamp fail to light the AVR is faulty and should be replaced.

Important ! After this test turn VOLTS control potentiometer fully anti-clockwise.

7.5.2.2 TRANSFORMER CONTROL

The transformer rectifier unit can only be checked by continuity, resistance checks and insulation resistance measurement.

Two phase transformer

Separate primary leads T1-T2-T3-T4 and secondary leads 10-11. Examine windings for damage. Measure resistances across T1-T3 and T2-T4. These will be a low value but should be balanced. Check that there is resistance in the order of 8 ohms between leads 10 and 11. Check insulation resistance of each winding section to earth and to other winding sections.

Low insulation resistance, unbalanced primary resistance, open or short circuited winding sections, indicates the transformer unit should be replaced.

Three phase transformer

Separate primary leads T1-T2-T3 and secondary leads 6-7-8 and 10-11-12.

Examine windings for damage. Measure resistances across T1-T2, T2-T3, T3-T1. These will be low but should be balanced. Check that resistances are balanced across 6-10, 7-11 and 8-12 and in the order of 18 ohms.

Check insulation resistance of each winding section to earth and to other winding sections.

Low insulation resistance, unbalanced primary or secondary winding resistances, open or short circuited winding sections indicates the transformer unit should be replaced.

Rectifier units - Three phase and single phase

With the leads 10-11-12-X and XX removed from the rectifier unit (lead 12 is not fitted on single phase transformer rectifier units), check forward and reverse resistances between terminals 10-X, 11-X, 12-X, 10-XX, 11-XX and 12-XX with a multimeter.

A low forward resistance and high reverse resistance should be read between each pair of terminals. If this is not the case the unit is faulty and should be replaced.

7.5.3 REMOVAL AND REPLACEMENT OF COMPONENT ASSEMBLIES

METRIC THREADS ARE USED THROUGHOUT

Caution ! When lifting single bearing generators, care is needed to ensure the generator frame is kept in the horizontal plane. The rotor is free to move in the frame and can slide out if not correctly lifted. Incorrect lifting can cause serious personal injury.

7.5.3.1 REMOVAL OF PERMANENT MAGNET GENERATOR (PMG)

1. Remove 4 screws holding the sheet metal cylindrical cover at the non-drive end and remove the cover.
2. Disconnect the in line connector from the PMG stator (3 wires go to this connector). It may be necessary to cut off the nylon cable tie first.
3. Remove the 4 threaded pillars and clamps holding the PMG stator onto the end bracket.
4. Tap the stator out of the 4 spigots and withdraw. The highly magnetic rotor will attract the stator. Take care to avoid contact which may damage the windings.
5. Remove the bolt in the centre from the rotor shaft and pull off the rotor. It may be necessary to gently tap the rotor away. Take care to tap gently and evenly - the rotor has ceramic magnets which are easily broken by shock.

Important ! The rotor assembly must not be dismantled.

Replacement is a reversal of the above procedure.

7.5.3.2 REMOVAL OF BEARINGS

Important ! Position the main rotor so that a full pole face of the main rotor core is at the bottom of the stator bore.

NOTE: Removal of the bearings may be effected either after the rotor assembly has been removed OR more simply by removal of endbracket(s). Refer to 7.5.3.3. and 7.5.3.4.

The bearings are pre-packed with grease and sealed for life.

The bearing(s) are a press fit and can be removed from the shaft with 3 leg or 2 leg manual or hydraulic bearing pullers.

SINGLE BEARING ONLY: Before trying to pull off the bearing remove the small circlip retaining it.

When fitting new bearings use a bearing heater to expand the bearing before fitting to the shaft. Tap the bearing into place ensuring that it contacts the shoulder on the shaft.

Refit the retaining circlip on single bearing generators.

7.5.3.3 REMOVAL OF ENDBRACKET AND EXCITER STATOR

1. Remove exciter leads X+, XX- at the AVR.
2. Slacken 4 bolts (2 each side) situated on horizontal centre line holding the terminal box.
3. Remove 2 bolts holding lifting lug, at the non-drive end, and remove lug.

4. Remove sheet metal cylindrical cover (4 screws) over PMG (if fitted)
or
Remove shallow sheet metal cover (4 screws) at the non-drive end.
5. Ease up the terminal box and support clear of the non-drive endbracket.
6. Remove 6 bolts holding the non-drive endbracket to the stator bar assembly. The endbracket is now ready for removal.
7. Replace the lifting lug onto the endbracket and sling the endbracket on a hoist to facilitate lifting.
8. Tap the endbracket around its perimeter to release from the generator. The endbracket and exciter stator will come away as a single assembly.
9. Remove the 4 screws holding the exciter stator to the endbracket and gently tap the exciter stator to release it. Replacement is a reversal of the above procedure.

7.5.3.4 REMOVAL OF THE ROTOR ASSEMBLY

Remove the permanent magnet generator. Refer to 7.5.3.1 or
Remove the four screws holding the sheet metal cover at the non drive end and remove cover.

Caution ! With the PMG rotor removed single bearing generator rotors are free to move in the frame. Ensure frame is kept in the horizontal plane when lifting.

TWO BEARING GENERATORS

1. Remove 2 screws holding the sheet metal cover around the adaptor at the drive end and remove the cover.
2. Remove the bolts holding the adaptor to the endbracket at the drive end.
3. Tap off the adaptor. It may be preferred to sling the adaptor first depending on its size and weight.
4. Remove the screens and louvres (if fitted) at each side on the drive end.

Now ensure that the rotor is positioned with a full pole face at the bottom centre line. This is to avoid damage to the bearing exciter, or rotor winding, by limiting the possible rotor downward movement to the air gap length.

5. Remove 6 bolts holding drive endbracket onto adaptor ring DE. The boltheads face towards the non-drive end. The top bolt passes through the centre of the lifting lug.
6. Tap the drive endbracket away from the adaptor ring DE and withdraw the endbracket.
7. Ensure the rotor is supported at the drive end on a sling.
8. Tap the rotor from the non-drive end to push the bearing clear of the endbracket and its position within an 'O' ring.
9. Continue to push the rotor out of the stator bore, gradually working the sling along the rotor as it is withdrawn, to ensure that it is fully supported all the time.

SINGLE BEARING GENERATORS

1. Remove the screws, screens and louvres (if fitted) at each side on drive end adaptor.
2. **UCI224, UCI274, UCM224, UCM274, UCD274 Only**

Remove 6 bolts holding the adaptor at the drive end. It may be preferred to sling the adaptor on a hoist. The bolt heads face towards the non-drive end. The top bolt passes through the centre of the lifting lug.

2a. **UCD224 Only**

Remove 6 bolts holding the adaptor at the drive end. It may be preferred to sling the adaptor on a hoist.

3. **UCI224, UCI274, UCM224, UCM274, UCD274 Only**

Tap the adaptor away from stator bar adaptor ring.

3a. **UCD224 Only**

Tap the adaptor away from stator bar assembly.

ALL SINGLE BEARING GENERATORS

4. Ensure the rotor is supported at drive end on a sling.
5. Tap the rotor from the non-drive end to push the bearing clear of the endbracket and its position within an 'O' ring.
6. Continue to push the rotor out of the stator bore, gradually working the sling along the rotor as it is withdrawn, to ensure that it is fully supported at all times.

Replacement of rotor assemblies is a reversal of the procedures above.

Before commencing re-assembly, components should be checked for damage and bearing(s) examined for loss of grease.

Fitting of new bearing(s) is recommended during major overhaul.

Before replacement of a single bearing rotor assembly, check that the drive discs are not damaged, cracked or showing other signs of fatigue. Also check that the holes in the discs for drive fixing screws are not elongated.

Damaged or worn components must be replaced.

Caution ! When major components have been replaced, ensure that all covers and guards are securely fitted, before the generator is put into service.

7.6 RETURNING TO SERVICE

After rectification of any faults found, remove all test connections and reconnect all control system leads.

Restart the set and adjust VOLTS control potentiometer on AVR controlled generators by slowly turning clockwise until rated voltage is obtained.

Refit all terminal box covers/access covers and reconnect heater supply.

Caution ! Failure to refit all guards, access covers and terminal box covers can result in personal injury of death.

SECTION 8

SPARES AND AFTER SALES SERVICE

8.1 RECOMMENDED SPARES

Service parts are conveniently packaged for easy identification. Genuine parts may be recognised by the Nupart name.

We recommend the following for Service and Maintenance. In critical applications a set of these service spares should be held with the generator.

AVR Controlled Generators

1. Diode Set (6 diodes with surge suppressor)	RSK	2001	
2. AVR SX440	E000	24030	
AVR SX460	E000	24602	
AVR SX421	E000	24210	
AVR MX321	E000	23212	
AVR MX341	E000	23410	
3. Non drive end Bearing	UC22	051	01032
	UC27	051	01049
4. Drive end Bearing	UC22	051	01044
	UC27	051	01050

Transformer Controlled Generators (UC22 Only)

1. Diode Set (6 diodes with surge suppressor)	RSK	2001	
2. Diode Assembly	E000	22006	
3. Non drive end Bearing	UC22	051	01032
4. Drive end Bearing	UC22	051	01044

When ordering parts the machine serial number or machine identity number and type should be quoted, together with the part description. For location of these numbers see paragraph 1.3.

Orders and enquiries for parts should be addressed to:

Newage International Limited
Nupart Department
PO Box 17, Barnack Road
STAMFORD
Lincolnshire
PE9 2NB
ENGLAND

Telephone: 44 (0) 1780 484000

Fax: 44 (0) 1780 766074

Or any of our subsidiary companies listed on the back cover.

8.2 AFTER SALES SERVICE

A full technical advice and on-site service facility is available from our Service Department at Stamford or through our Subsidiary Companies. A repair facility is also available at our Stamford Works.

PARTS LIST
TYPICAL SINGLE BEARING GENERATOR

Plate Ref.	Description	Plate Ref.	Description
1	Stator	25	Main Rectifier Assembly - Reverse
2	Rotor	26	Varistor
3	Exciter Rotor	27	Diode - Forward Polarity
4	Exciter Stator	28	Diode - Reverse Polarity
5	N.D.E. Bracket	29	Lifting Lug - D.E.
6	Cover N.D.E.	30	Lifting Lug - N.D.E.
7	Bearing 'O' Ring N.D.E.	31	Frame to Endbracket Adaptor Ring
8	Bearing N.D.E.	32	Main Terminal Panel
9	Bearing Circlip N.D.E.	33	Terminal Link
10	D.E. Bracket/Engine Adaptor	34	Edging Strip
11	D.E. Screen	35	Fan
12	Coupling Disc	36	Foot Mounting Spacer
13	Coupling Bolt	37	Cap Screw
14	Foot	38	AVR Access Cover
15	Frame Cover Bottom	39	AVR Anti-Vibration Mounting Assembly
16	Frame Cover Top	40	Auxiliary Terminal Assembly
17	Air Inlet Cover		
18	Terminal Box Lid		
19	Endpanel D.E.		
20	Endpanel N.D.E.		
21	AVR		
22	Side Panel		
23	AVR Mounting Bracket		
24	Main Rectifier Assembly - Forward		

N.D.E. Non Drive End
D.E. Drive End
PMG Permanent Magnet Generator
AVR Automatic Voltage Regulator

Fig. 11.
TYPICAL SINGLE BEARING GENERATOR

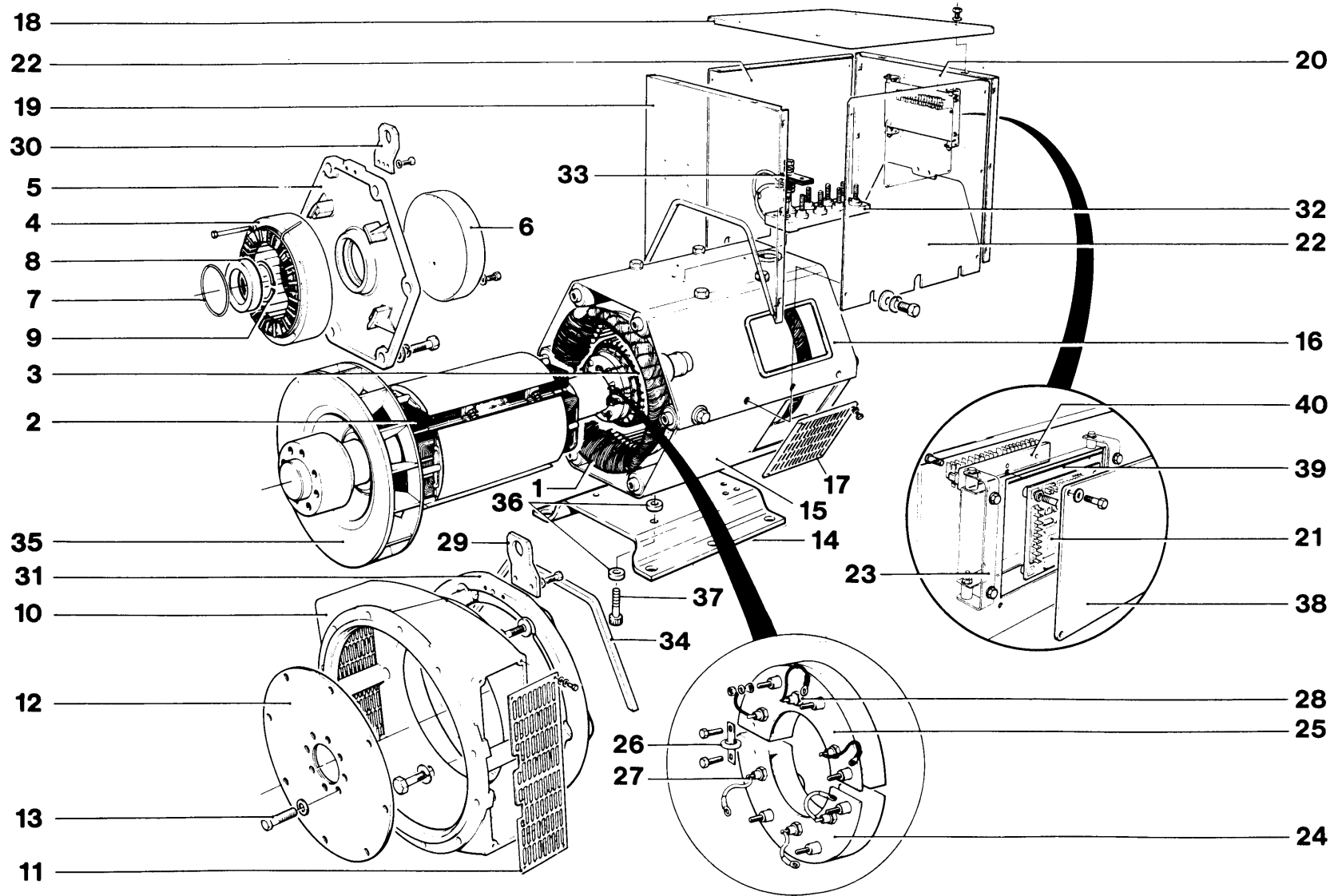

PARTS LIST
TYPICAL TWO BEARING GENERATOR

Plate Ref.	Description	Plate Ref.	Description
1	Stator	25	Main Rectifier Assembly - Reverse
2	Rotor	26	Varistor
3	Exciter Rotor	27	Diode - Forward Polarity
4	Exciter Stator	28	Diode - Reverse Polarity
5	N.D.E. Bracket	29	Lifting Lug - D.E.
6	Cover N.D.E.	30	Lifting Lug - N.D.E.
7	Bearing 'O' Ring N.D.E.	31	Frame to Endbracket Adaptor Ring
8	Bearing N.D.E.	32	Main Terminal Panel
9	Bearing Wave Washer D.E.	33	Terminal Link
10	D.E. Bracket	34	Edging Strip
11	D.E. Screen	35	Fan
12	Bearing D.E.	36	Foot Mounting Spacer
14	Foot	37	Cap Screw
15	Frame Cover Bottom	38	AVR Access Cover
16	Frame Cover Top	39	AVR Anti-Vibration Mount
17	Air Inlet Cover	40	Auxiliary Terminal Assembly
18	Terminal Box Lid	42	PMG Exciter Rotor
19	Endpanel D.E.	43	PMG Exciter Stator
20	Endpanel N.D.E.	44	PMG Bolt
21	AVR	45	PMG Pillar
22	Side Panel	46	PMG Clamp
23	AVR Mounting Bracket	47	PMG Dowel
24	Main Rectifier Assembly - Forward		

N.D.E. Non Drive End
D.E. Drive End
PMG Permanent Magnet Generator
AVR Automatic Voltage Regulator

Fig. 12.
TYPICAL TWO BEARING GENERATOR

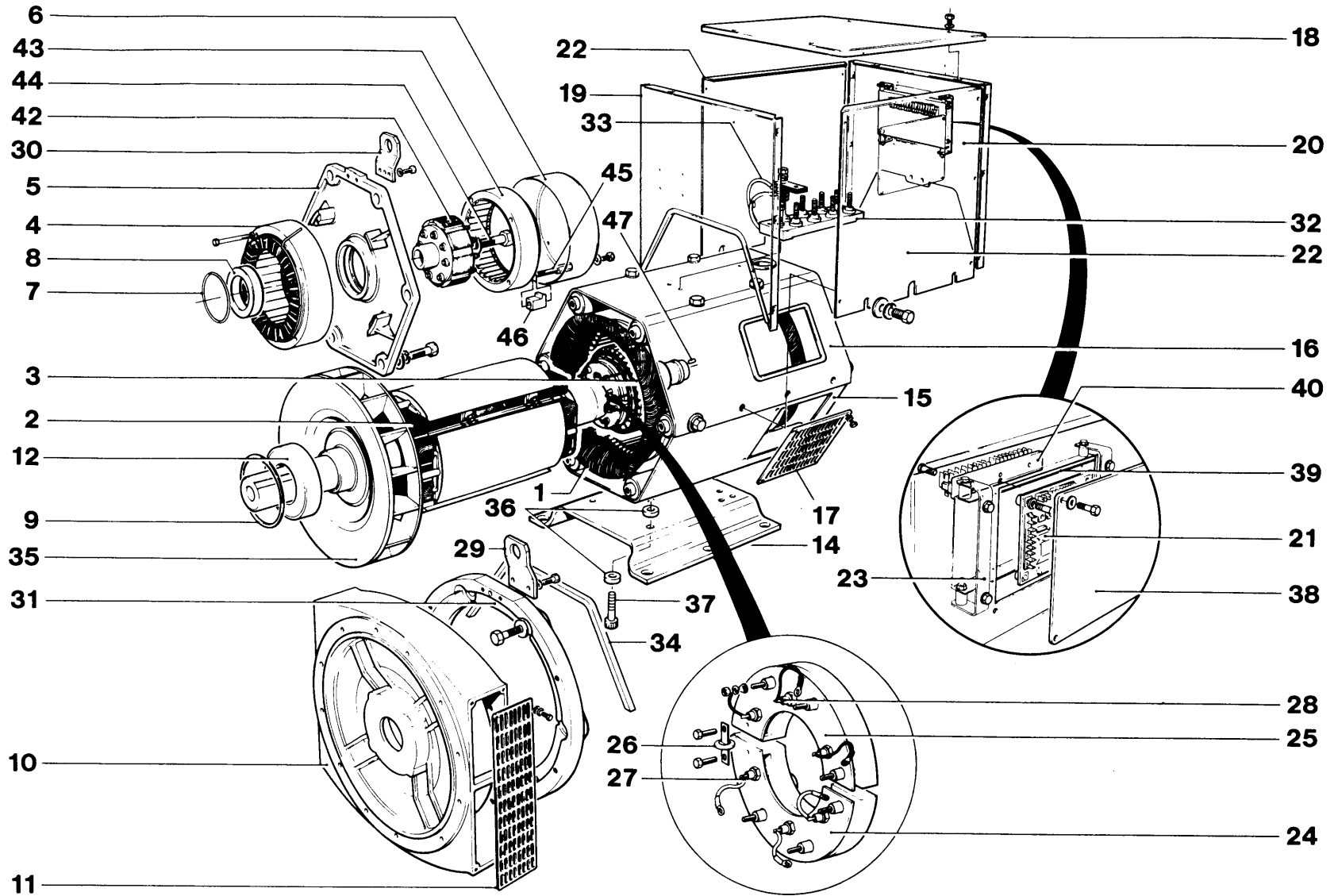

PARTS LIST
TYPICAL TWO BEARING (SERIES 5) GENERATOR

Plate Ref.	Description	Plate Ref.	Description
1	Stator	25	Main Rectifier Assembly - Reverse
2	Rotor	26	Varistor
3	Exciter Rotor	27	Diode - Forward Polarity
4	Exciter Stator	28	Diode - Reverse Polarity
5	N.D.E. Bracket	29	Lifting Lug - D.E.
6	Cover N.D.E.	30	Lifting Lug - N.D.E.
7	Bearing 'O' Ring N.D.E.	31	Frame to Endbracket Adaptor Ring
8	Bearing N.D.E.	32	Main Terminal Panel
9	Bearing Wave Washer D.E.	33	Terminal Link
10	D.E. Bracket	34	Edging Strip
11	D.E. Screen	35	Fan
12	Bearing D.E.	36	Foot Mounting Spacer
13		37	Cap Screw
14	Foot		
15	Frame Cover Bottom		
16	Frame Cover Top		
17	Air Inlet Cover		
18	Terminal Box Lid		
19	Endpanel D.E.		
20	Endpanel N.D.E.		
21	Series 5 Control Gear		
22	Side Panel		
23			
24	Main Rectifier Assembly - Forward		

N.D.E. Non Drive End
D.E. Drive End

Fig. 13.
TYPICAL TWO BEARING (SERIES 5) GENERATOR

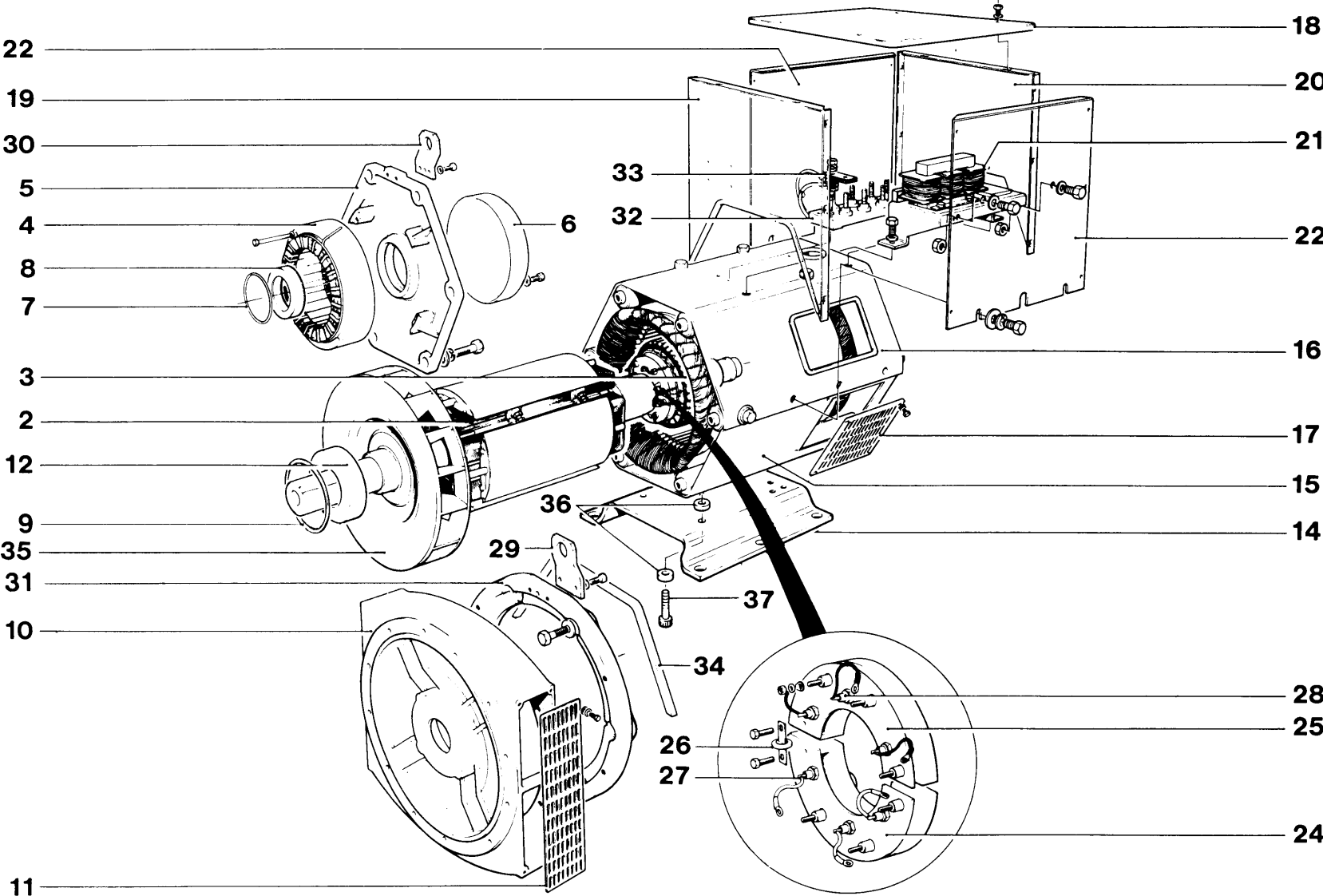

Fig. 14.
ROTATING RECTIFIER ASSEMBLY

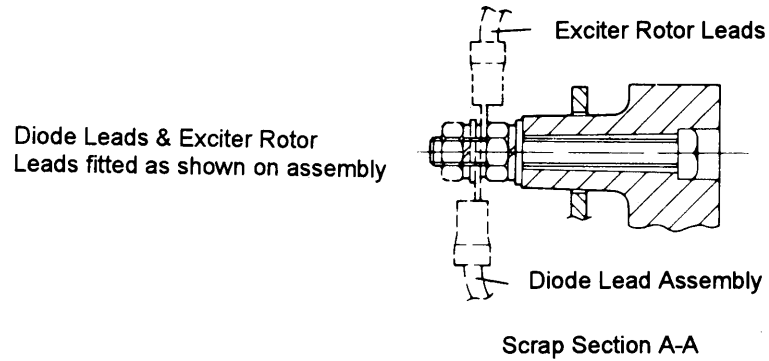
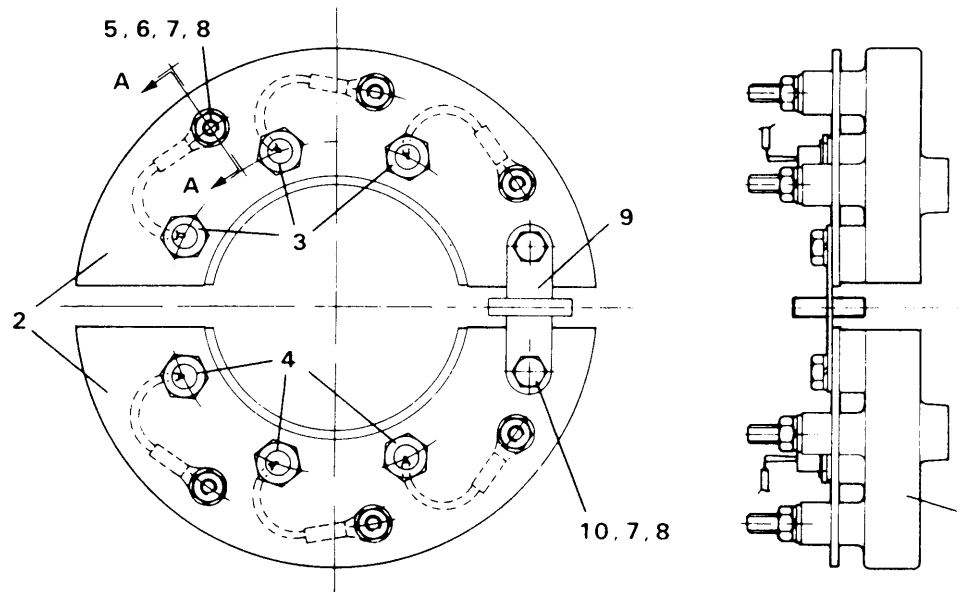

Plate Ref.	Description	Qty
1	Hub	1
2	Fin	2
3	Diode (fwd)	3
4	Diode (rev)	3
5	Hx. Screw	6
6	Hx. Nut	6
7	Pl. Washer	8
8	SC. L/Washer	8
9	Varistor	1
10	Hx. Screw	2

NOTES:
Fitting of Diodes.

1. Underside of diodes to be smeared with Midland Silicone 'Heat Sink' compound type MS2623. This compound **must not** be applied to the diode threads.
2. Diodes to be tightened to a torque of 2.03 - 2.37 Nm.
3. For Nupart rectifier service kit see page 28.



This manual is available in the following languages on request:
English, French, German, Italian and Spanish.

Denne manual er til rådighed på følgende sprog: engelsk, fransk, tysk, italiensk og spansk.

Denne håndboken er tilgjengelig på de følgende språkene: engelsk, fransk, tysk, italiensk og spansk.

Sur simple demande, ce manuel vous sera fourni dans l'une des langues suivantes: anglais, français, allemand, italien, espagnol.

Dieses Handbuch ist auf Anfrage in den folgenden Sprachen erhältlich: Englisch, Französisch, Deutsch, Italienisch, Spanisch.

Deze handleiding is op verzoek leverbaar in de volgende talen: Engels, Frans, Duits, Italiaans, Spaans.

Este manual pode também ser obtido nas seguintes línguas: inglês, francês, alemão, italiano e espanhol.

Tämä käsikirja on saatavissa pyynnöstä seuraavilla kielillä: Englanti, ranska, saksa, italia, espanja.

Il presente manuale è disponibile, su richiesta, nelle seguenti lingue: inglese, francese, tedesco, italiano e spagnolo.

Este manual también puede solicitarse en los siguientes idiomas: inglés, francés, alemán, italiano e español.

Αυτό το εγχειρίδιο οδηγιών χρήσεως διατίθεται στις ακόλουθες γλώσσες κατόπιν αιτήσεως: Αγγλικά, Γαλλικά, Γερμανικά, Ιταλικά, Ισπανικά.

A.C. GENERATOR WARRANTY

WARRANTY PERIOD

A.C. Generators

In respect of a.c. generators the Warranty Period is eighteen months from the date when the goods have been notified as ready for despatch by N.I. or twelve months from the date of first commissioning (whichever is the shorter period).

DEFECTS AFTER DELIVERY

We will make good by repair or, at our option, by the supply of a replacement, any fault which under proper use appears in the goods within the period specified on Clause 12, and is found on examination by us to be solely due to defective material and workmanship; provided that the defective part is promptly returned, carriage paid, with all identification numbers and marks intact, or our works or, if appropriate to the Dealer who supplied the goods.

Any part repaired or replaced, under warranty, will be returned by N.I. free of charge (via sea freight if outside the UK).

We shall not be liable for any expenses which may be incurred in removing or replacing any part sent to us for inspection or in fitting any replacement supplied by us. We shall be under no liability for defects in any goods which have not been properly installed in accordance with N.I. recommended installation practices as detailed in the publications 'N.I. Installation, Service and Maintenance Manual' and 'N.I. Application Guidelines', or which have been improperly stored or which have been repaired, adjusted or altered by any person except ourselves or our authorised agents, or in any second-hand goods, proprietary articles or goods not of our own manufacture although supplied by us, such articles and goods being covered by the warranty (if any) given by the separate manufacturers.

Any claim under this clause must contain fully particulars of the alleged defect, the description of the goods, the date of purchase, and the name and address of the Vendor, the Serial Number (as shown on the manufacturers identification plate) or for Spares the order reference under which the goods were supplied.

Our judgement in all cases of claims shall be final and conclusive and the claimant shall accept our decision on all questions as to defects and the exchange of a part or parts.

Our liability shall be fully discharged by either repair or replacement as above, and in any event shall not exceed the current list price of the defective goods.

Our liability under this clause shall be in lieu of any warranty or condition implied by law as to the quality or fitness for any particular purpose of the goods, and save as expressly provided in this clause we shall not be under any liability, whether in contract, tort or otherwise, in respect of defects in goods delivered or for any injury, damages or loss resulting from such defects or from any work undone in connection therewith.

MACHINE SERIAL NUMBER

NEWAGE INTERNATIONAL LIMITED

REGISTERED OFFICE AND ADDRESS:

PO BOX 17
BARNACK ROAD
STAMFORD
LINCOLNSHIRE
PE9 2NB ENGLAND

Telephone: 44 (0) 1780 484000

Fax: 44 (0) 1780 484100

Web site: www.newagestamford.com

SUBSIDIARY COMPANIES



1 AUSTRALIA: NEWAGE ENGINEERS PTY. LIMITED
PO Box 6027, Baulkham Hills Business Centre,
Baulkham Hills NSW 2153.
Telephone: Sydney (61) 2 9680 2299
Fax: (61) 2 9680 1545

2 CHINA: WUXI NEWAGE ALTERNATORS LIMITED
Plot 49-A, Xiang Jiang Road
Wuxi High - Technical Industrial Dev. Zone
Wuxi, Jiangsu 214028
PR of China
Tel: (86) 510 5216212
Fax: (86) 510 5217673

3 GERMANY: NEWAGE ENGINEERS G.m.b.H.
Rotenbrückenweg 14, D-22113 Hamburg.
Telephone: Hamburg (49) 40 714 8750
Fax: (49) 40 714 87520

4 INDIA: C.G. NEWAGE ELECTRICAL LIMITED
C33 Midc, Ahmednagar 414111, Maharashtra.
Telephone: (91) 241 778224
Fax: (91) 241 777494

5 ITALY: NEWAGE ITALIA S.r.l.
Via Triboniano, 20156 Milan.
Telephone: Milan (39) 02 380 00714
Fax: (39) 02 380 03664

6 JAPAN: NEWAGE INTERNATIONAL JAPAN
8 - 5 - 302 Kashima
Hachioji-shi
Tokyo, 192-03
Telephone: (81) 426 77 2881
Fax: (81) 426 77 2884

7 NORWAY: NEWAGE NORGE A/S
Økern Naeringspark, Kabeigt. 5
Postboks 28, Økern, 0508 Oslo
Telephone: Oslo (47) 22 97 44 44
Fax: (47) 22 97 44 45

8 SINGAPORE: NEWAGE ASIA PACIFIC PTE LIMITED
10 Toh Guan Road #05-03
TT International Tradepark
Singapore 608838
Telephone: Singapore (65) 794 3730
Fax: (65) 898 9065
Telex: RS 33404 NEWAGE

9 SPAIN: STAMFORD IBERICA S.A.
Ctra. Fuenlabrada-Humanes, km.2
Poligono Industrial "Los Linares"
C/Pico de Almanzor, 2
E-28970 HUMANES DE MADRID (Madrid)
Telephone: Madrid (34) 91 604 8987/8928
Fax: (34) 91 604 81 66

10 U.S.A.: NEWAGE LIMITED
4700 Main St, N.E.
Fridley
Minnesota 55421
Telephone: (1) 800 367 2764
Fax: (1) 800 863 9243