



Microelettrica Scientifica

IM30-B00

Doc. N° MO-0132-ING

Rev. 1

Date 20.02.2003

# MICROPROCESSOR EARTH FAULT PROTECTION RELAY

## TYPE IM30-B00

# OPERATION MANUAL

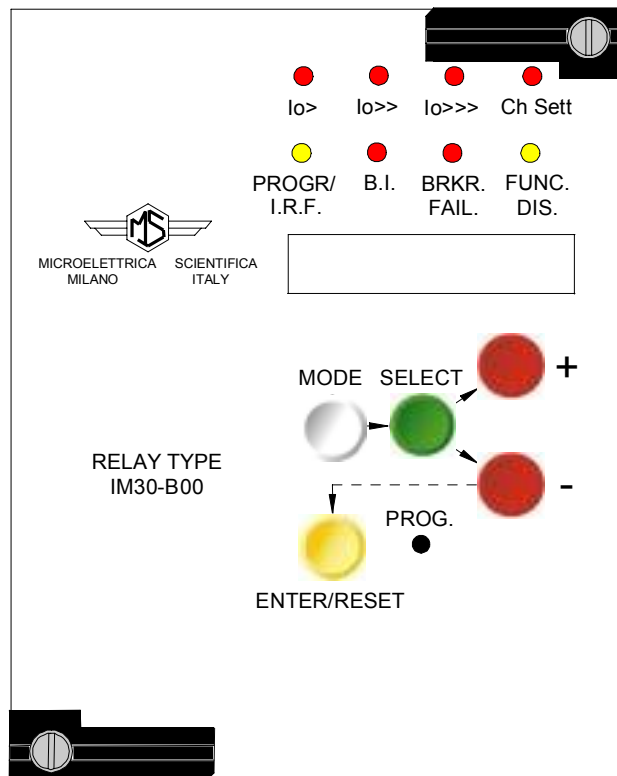



INDEX

1	General utilization and commissioning directions	3
1.1	Storage and transportation	3
1.2	Installation	3
1.3	Electrical connection	3
1.4	Measuring inputs and power supply	3
1.5	Outputs loading	3
1.6	Protection earthing	3
1.7	Setting and calibration	3
1.8	Safety protection	3
1.9	Handling	3
1.10	Maintenance	4
1.11	Fault detection and repair	4
2	General characteristics and operation	4
2.1	Power supply	4
2.2	Algorithm of the time current curves	5
2.3	Clock and Calendar	6
2.3.1	Clock synchronization	6
2.3.2	Date and time setting	6
2.3.3	Time resolution	6
2.3.4	Operation during power off	6
2.3.5	Time tolerance	6
3	Controls and measurements	7
4	Signalization	8
5	Output relays	9
6	Serial communication	9
7	Digital inputs	10
8	Test	10
9	Keyboard and display operation	11
10	Reading of measurements and recorded parameters	12
10.1	ACT. MEAS (Actual measure)	12
10.2	LASTTRIP (Last trip)	12
10.3	TRIP NUM (Trip number)	12
11	Reading of programmed settings and relay's configuration	13
12	Programming	13
12.1	Programming of functions settings	13
12.2	Programming the configuration of output relay	14
13	Manual and automatic test operation	15
13.1	Mode "TESTPROG" subprogram "W/O TRIP"	15
13.2	Mode "TESTPROG" subprogram "With TRIP"	15
14	Maintenance	15
15	Electrical characteristics	16
16	Connection diagram (Standard Output)	17
17	Wiring the serial communication bus	17
18	Time current curves IEC	18
19	Time current curves IEEE	19
20	Direction for pcb's draw-out and plug-in	20
20.1	Draw-out	20
20.2	Plug-in	20
21	Overall dimensions	21
22	Keyboard operational diagram	22
23	Setting's form	23



## 1. General utilization and commissioning directions

Always make reference to the specific description of the product and to the Manufacturer's instruction. Carefully observe the following warnings.

### 1.1 - STORAGE AND TRANSPORTATION

must comply with the environmental conditions stated on the product's instruction or by the applicable IEC standards.

### 1.2 - INSTALLATION

must be properly made and in compliance with the operational ambient conditions stated by the Manufacturer.

### 1.3 - ELECTRICAL CONNECTION

must be made strictly according to the wiring diagram supplied with the Product, to its electrical characteristics and in compliance with the applicable standards particularly with reference to human safety.

### 1.4 - MEASURING INPUTS AND POWER SUPPLY

carefully check that the value of input quantities and power supply voltage are proper and within the permissible variation limits.

### 1.5 - OUTPUTS LOADING

must be compatible with their declared performance.

### 1.6 - PROTECTION EARTHING

When earthing is required, carefully check its effectiveness.

### 1.7 - SETTING AND CALIBRATION

Carefully check the proper setting of the different functions according to the configuration of the protected system, the safety regulations and the co-ordination with other equipment.

### 1.8 - SAFETY PROTECTION

Carefully check that all safety means are correctly mounted, apply proper seals where required and periodically check their integrity.

### 1.9 - HANDLING

Notwithstanding the highest practicable protection means used in designing M.S. electronic circuits, the electronic components and semiconductor devices mounted on the modules can be seriously damaged by electrostatic voltage discharge which can be experienced when handling the modules. The damage caused by electrostatic discharge may not be immediately apparent but the design reliability and the long life of the product will have been reduced. The electronic circuits reduced by M.S. are completely safe from electrostatic discharge (8 KV IEC 255.22.2) when housed in their case; withdrawing the modules without proper cautions expose them to the risk of damage.



- a. Before removing a module, ensure that you are at the same electrostatic potential as the equipment by touching the case.
- b. Handle the module by its front-plate, frame, or edges of the printed circuit board. Avoid touching the electronic components, printed circuit tracks or connectors.
- c. Do not pass the module to any person without first ensuring that you are both at the same electrostatic potential. Shaking hands achieves equipotential.
- d. Place the module on an antistatic surface, or on a conducting surface which is at the same potential as yourself.
- e. Store or transport the module in a conductive bag.

More information on safe working procedures for all electronic equipment can be found in BS5783 and IEC 147-OF.

1.10 - MAINTENANCE

Make reference to the instruction manual of the Manufacturer; maintenance must be carried-out by specially trained people and in strict conformity with the safety regulations.

1.11 - FAULT DETECTION AND REPAIR

Internal calibrations and components should not be altered or replaced. For repair please ask the Manufacturer or its authorised Dealers.

Misapplication of the above warnings and instruction relieves the Manufacturer of any liability.

2. GENERAL

Input currents are supplied to 2 current transformers measuring the earth fault zero-sequence current. The first (HI = High Input) supplied from terminals 29 – 28 (5A) or 29 – 30 (1A) operates the third high-set Earth Fault element 3I. The second (LI = Low Input) supplied from terminals 32 – 31 (5A) or 32 – 33 (1A) operates the first and the second Low-set Earth Fault elements 1I, 2I. Taps for 1A and 5A input are provided on relay's terminal board. Make electric connection in conformity with the diagram reported on relay's enclosure. Check that input currents are same as reported on the diagram and on the test certificate.

2.1 - POWER SUPPLY

The auxiliary power is supplied by a built-in interchangeable module fully isolated and self protected. The relay can be fitted with two different types of power supply module :

- |                             |                             |                             |
|-----------------------------|-----------------------------|-----------------------------|
| a) - {                      | {                           | b) - {                      |
| 24V(-20%) / 110V(+15%) a.c. | 80V(-20%) / 220V(+15%) a.c. | 90V(-20%) / 250V(+20%) d.c. |
| 24V(-20%) / 125V(+20%) d.c. | }                           | }                           |

Before energising the unit check that supply voltage is within the allowed limits.



## 2.2 - ALGORITHM OF THE TIME CURRENT CURVES

The Time Current Curves are generally calculated with the following equation :

$$(1) \quad t(I) = \left[ \frac{A}{\left(\frac{I}{I_s}\right)^a - 1} + B \right] \bullet K \bullet T_s + t_r \quad \text{where :}$$

$t(I)$  = Actual trip time delay when the input current equals  $I$

$I_s$  = Set minimum pick-up level

$$K = \left( \frac{A}{10^a - 1} + B \right)^{-1}$$

$T_s$  = Set time delay :  $t(I) = T_s$  when  $\frac{I}{I_s} = 10$

$t_r$  = Operation time of the output relay on pick-up.

The parameters A, B and a have different values for the different Time Current Curves.

Curve Name	Curve Identifier	A	B	a
IEC A Inverse	A	0.14	0	0.02
IEC B Very Inverse	B	13.5	0	1
IEC C Extremely Inverse	C	80	0	2
IEEE Moderate Inverse	MI	0.0104	0.0226	0.02
IEEE Short Inverse	SI	0.00342	0.00262	0.02
IEEE Very Inverse	VI	3.88	0.0963	2
IEEE Inverse	I	5.95	0.18	2
IEEE Extremely Inverse	EI	5.67	0.0352	2

For the IEC curves, being  $B = 0$ , the Time/Current equation (1), becomes:

$$(1') = \frac{(10^a - 1)T_s}{\left(\frac{I}{I_s}\right)^a - 1} + t_r = \frac{Kt}{\left(\frac{I}{I_s}\right)^a - 1} + t_r$$

Where  $Kt = (10^a - 1)T_s$  is the time multiplier



## 2.3 - CLOCK AND CALENDAR

The unit features a built in clock calendar with Years, Months, Days, Hours, Minutes, Seconds, Tenths of seconds and Hundredths of seconds.

### 2.3.1 - Clock synchronization.

The clock can be synchronized via the serial communication interface.

The following synchronization periods can be set: 5, 10, 15, 30, 60 minutes.

Synchronization can also be disabled, in which case the relay ignores the serial broadcast signal.

In case synchronization is enabled, the unit expects to receive a sync signal at the beginning of every hour and once every  $T_{syn}$  minutes. When a sync signal is received, the clock is automatically set to the nearest expected synchronization time.

For example: if  $T_{syn}$  is 10min and a sync signal is received at 20:03:10 January the 10<sup>th</sup>, 98, then the clock is set to 20:00:00 January the 10<sup>th</sup>, 1998.

On the other hand, if the same sync signal were received at 20:06:34, the clock would be set to 20:10:00, January the 10<sup>th</sup> 98.

Note that if a sync signal is received exactly in the middle of a  $T_{syn}$  period, the clock is set to the previous expected synchronization time.

### 2.3.2 - Date and time setting.

When the PROG/SETTINGS menu is entered, the current date is displayed with one of the groups of digits (YY, MMM or DD) blinking.

The DOWN key operates as a cursor. It moves through the groups of digits in the sequence YY => MMM => DD => YY => ...

The UP key allows the user to modify the currently blinking group of digits.

If the ENTER button is pressed the currently displayed date is set.

Pressing the SELECT button the current time is displayed which can be modified using the same procedure as for the date.

If synchronization is enabled and the date (or time) is modified, the clock is stopped until a sync signal is received via the serial port. This allows the user to manually set many units and have them to start their clocks in a synchronized fashion.

If synchronization is disabled the clock is never stopped.

Note that the setting of a new time always clears 10ths and 100ths of sec.

### 2.3.3 - Time resolution.

The clock has a 10ms resolution. This means that any event can be time-stamped with a 10ms accuracy, although the information concerning 10ths and 100ths of sec. can be accessed only via the serial communication interface.

### 2.3.4 - Operation during power off.

The unit has an on board Real Time Clock which maintains time information for at least 1 hour in case of power supply failure.

### 2.3.5 - Time tolerance.

During power on, time tolerance depends on the on board crystal (+/-50ppm typ, +/-100ppm max. over full temperature range).

During power off, time tolerance depends on the RTC's oscillator (+65 /-270 ppm max over full temperature range).

### 3. CONTROLS AND MEASUREMENTS

Five key buttons allow for local management of all relay's functions.  
A 8-digit high brightness alphanumerical display shows the relevant readings (xxxxxxx)  
(see synoptic table fig.1)

FIG.1

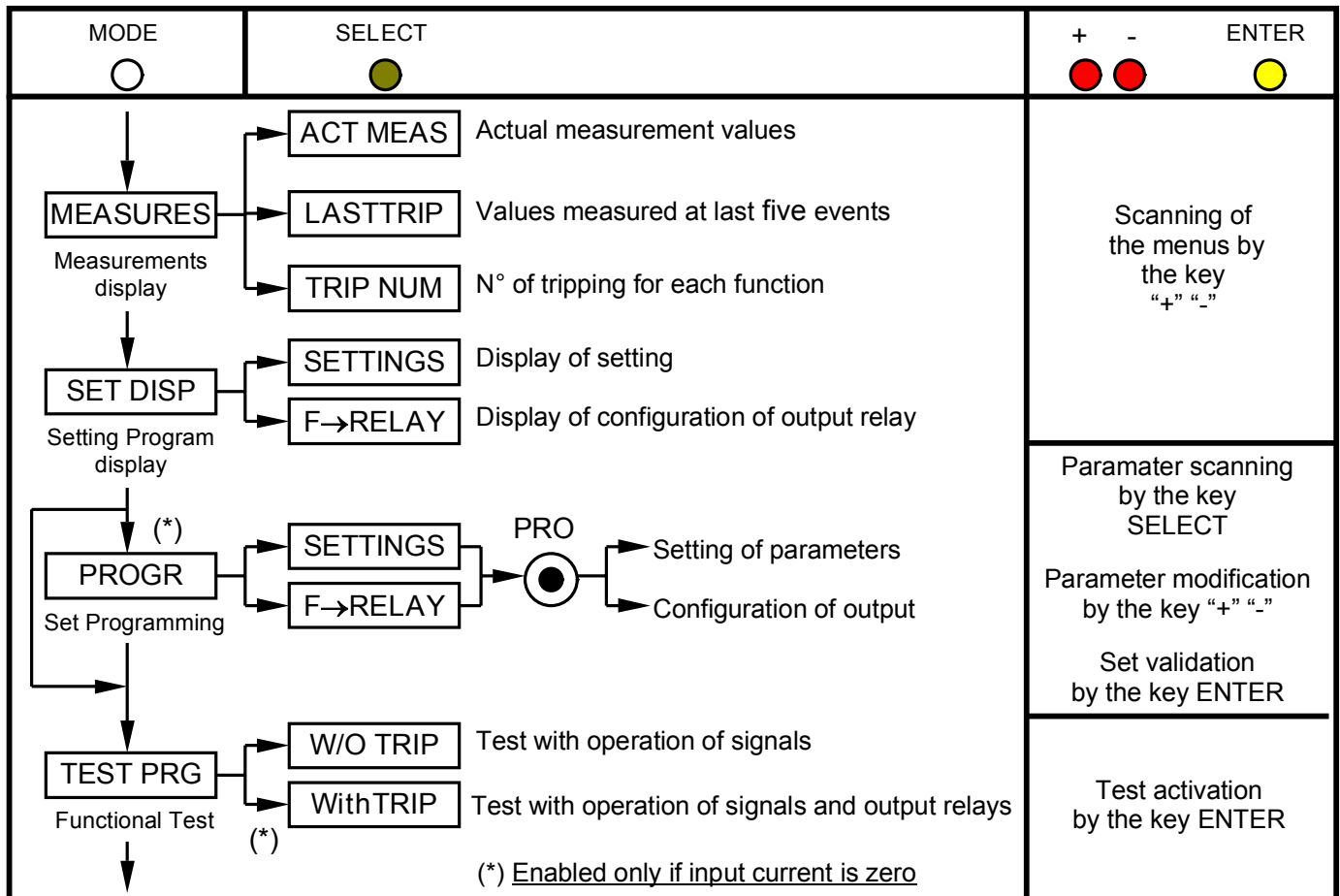

Pressing this button progressively selects between Measurements Display, Setting Display, Programming, and Test modes

The SELECT button chooses which category of values within the chosen mode to display

When in Program mode, this button stores the newly selected value. If not in Program mode and the relay has tripped, this button resets the relay and all output contacts. If not tripped, this button restores the default display.

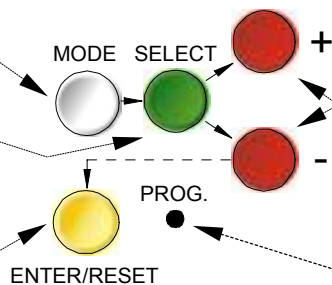

The + and - buttons are used to select the actual measurement or display desired when in Measurements Display or Settings Display modes. When in Program mode, these buttons increase or decrease the value of the displayed setting.

When in Program mode, and when all input currents are zero, pressing this recessed button places the relay into active programming mode, allowing any or all of the relay's settings to be altered.

#### 4. SIGNALIZATIONS

Eight signal leds (normally off) are provided:

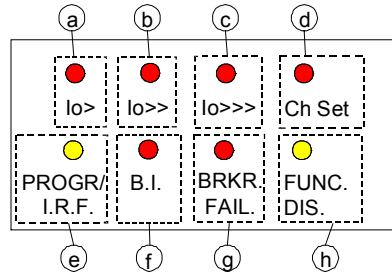

a) Red LED	Io>	<input type="checkbox"/> Flashing when measured current exceeds the set trip level [1]. <input type="checkbox"/> Illuminated on trip after expiry of the set trip time delay [t1].
b) Red LED	Io>>	<input type="checkbox"/> Same as above related to [2], [t2].
c) Red LED	Io>>>	<input type="checkbox"/> Same as above related to [3], [t3].
d) Red LED	Ch Set	<input type="checkbox"/> Off when setting program 1 is active. <input type="checkbox"/> Illuminated when setting program 2 is active.
e) Yellow LED	PROGR/ I.R.F.	<input type="checkbox"/> Flashing during the programming of the parameters or in case of Internal Relay Fault.
f) Red LED	BLOCK INPUT	<input type="checkbox"/> Flashing when a blocking signal is present at the relevant input terminals.
g) Red LED	BR.FAIL.	<input type="checkbox"/> Lit-on when the BREAKER FAILURE function is activated.(see § 5)
h) Yellow LED	FUNC. DISAB.	<input type="checkbox"/> Lit-on when the operation of one or more of the relay functions has been disactivated in the programming.

The reset of the leds takes place as follows:

<input type="checkbox"/> Leds a,b,c,g :	<input type="checkbox"/> From flashing to off, automatically when the lit-on cause disappears. <input type="checkbox"/> From ON to OFF, by "ENTER/RESET" push button or via serial communication only if the tripping cause has disappeared.
<input type="checkbox"/> Leds d,e,f,h :	<input type="checkbox"/> From ON to OFF, automatically when the lit-on cause disappears.

In case of auxiliary power supply failure the status of the leds is recorded and reproduced when power supply is restored.

	<h1>IM30-B00</h1>	Doc. N° MO-0132-ING
		Rev. 1 Date 20.02.2003

## 5. OUTPUT RELAYS

Five output relays are available (R1, R2, R3, R4, R5)

a) - The relays R1,R2,R3,R4 are normally deenergized (energised on trip); these output relays are user programmable and any of them can be associated to any (one or more) of the IM30-AB's functions. One relay eventually associated to the instantaneous element of one of the functions, after pick-up, normally drops-out as soon as the tripping cause disappears (current below the set trip level). If the current remains above the trip level longer than the time delay programmed for the time delayed element of the some function, the drop-out of the instantaneous relay is anyhow forced after an adjustable waiting time [tBF]. (Diasactivation of the blocking output eventually used to block a relay upstream in the distribution system). The timer tBF is also started at any time the relay R1 picks-up and any relays R2, R3, R4 can be programmed to be energized at the end of the delay tBF (Breaker Failure functions).

Reset of the output relays associated to any time delayed function can be programmed to take place "Automatically" (tFRes= A) as soon as the tripping cause has disappeared, or "Manually" (tFRes= M) only by operating the ENTER/RESET key on relay's front or via the serial bus.

It has to be remarked that the programming structure does not allow to associate the same relay at the same time to instantaneous and delayed elements. Therefore any relay already associated to any time delayed element cannot be associated to any instantaneous element and viceversa.

b) - The relay R5, normally energised, is not programmable and it is deenergized on:

- internal fault
- power supply failure
- during the programming

## 6. SERIAL COMMUNICATION

The relays fitted with the serial communication option can be connected via a cable bus a fiber optic bus for interfacing with a Personal Computer (type IBM or compatible).

All the functionalities that can be operated locally (for example reading of input measurement and changing of relay's settings) are also possible via the serial communication interface.

Furthermore the serial port allows the user to read event recording and stored data.

The unit has a RS232 / RS485 interface and can be connected either directly to a P.C. via a dedicated cable or to a RS485 serial bus, allowing having many relays to exchange data with a single master P.C. using the same physical serial line. A RS485/232 converter is available on request.

The communication protocol is MODBUS RTU (only functions 3, 4 and 16 are implemented).

Each relay is identified by its programmable address code (NodeAd) and can be called from the P.C.

A dedicated communication software (MSCOM) for Windows 95/98/NT4 SP3 (or later) is available.

Please refer to the MSCOM instruction manual for more information Microelettrica Scientifica.



## 7. DIGITAL INPUTS

Three digital inputs are provided: they are active when the relevant terminals are shorted

- B2 (terminals 1 - 2) : it blocks the operation of the time delayed elements t1I and t2I.
- B3 (terminals 1 - 3) : it blocks the operation of the time delayed elements t3I.
- B4 (terminals 1 - 14) : Switching-over from Setting Program 1 (SP1) to Setting Program 2 (SP2)
  - Terminals 1 – 14 Open = Setting Program 1 active
  - Terminals 1 – 14 Shorted = Setting Program 2 active

The input B4 can also be activated via the serial communication port.  
In this case Switching-back from SP2 to SP1 can only be made via serial port.

Viceversa if the terminals 1 – 14 are shorted, switching-back from SP2 to SP1 cannot be made via the serial port.

When a function is blocked the pick-up of its time delayed output is inhibited. Programming allows to have the inhibition either permanent as long as the blocking input is active (tB2=Dis; tB3=Dis) or automatically removed after the expiry of the set trip time delay of the function involved plus an additional time 2tBF (tB2=2tBF; tB3=2tBF). By proper interconnection of the blocking inputs and outputs of different relays it is possible to configurate very efficient arrangements of logic fault discrimination as well as to feature a safe and quick breaker back-up protection.

## 8. TEST

Besides the normal "WATCHDOG" and "POWERFAIL" functions, a comprehensive program of self-test and self-diagnostic provides:

- Diagnostic and functional test, with checking of program routines and memory's content, run every time the aux. power is switched-on: the display shows the type of relay and its version number.
- Dynamic functional test run during normal operation every 15 min. (relay's operation is suspended for less than  $\leq 4$  ms). If any internal fault is detected, the display shows a fault message, the Led "PROG/IRF" illuminates and the relay R5 is deenergized.
- Complete test activated by the keyboard or via the communication bus either with or without tripping of the output relays.



### 9. KEYBOARD AND DISPLAY OPERATION

All controls can be operated from relay's front or via serial communication bus. The keyboard includes five hand operable buttons (MODE) - (SELECT) - (+) - (-) - (ENTER/RESET) plus one indirect operable key (PROG) (see synoptic table a fig.1):

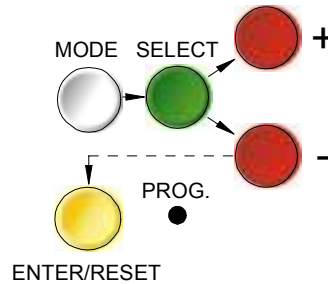

a) - White key	MODE	:	when operated it enters one of the following operation modes indicated on the display :
	MEASURES	=	Reading of all the parameters measured and of those recorded in the memory
	SET DISP	=	Reading of the settings and of the configuration of the output relays as programmed.
	PROG	=	Access to the programming of the settings and of relay configuration.
	TEST PROG	=	Access to the manual test routines.
b) - Green key	SELECT	:	When operated it selects one of the menus available in the actual operation MODE
c) - Red key	"+" AND "-"	:	When operated they allow to scroll the different information available in the menu entered by the key SELECT
d) - Yellow key	ENTER/RESET	:	It allows the validation of the programmed settings - the actuation of test programs - the forcing of the default display indication - the reset of signal Leds.
e) - Indirect key	●	:	Enables access to the programming.

	<h1>IM30-B00</h1>	Doc. N° MO-0132-ING
		Rev. 1 Date 20.02.2003

## 10. READING OF MEASUREMENTS AND RECORDED PARAMETERS

Enter the MODE "MEASURE", SELECT the menus "ACT.MEAS"- "LASTTRIP"- "TRIP NUM", scroll available information by key "+" or "-" .

### 10.1 - ACT.MEAS

Actual values as measured during the normal operation.  
The values displayed are continuously refreshed.

Display	Description
xxXXXxx	Date : Day, Month, Year
xx:xx:xx	Hour : Hours, Minutes, Seconds
HlxxxxxA	True R.M.S. value of the current supplied to terminals 29-30, displayed as primary Amps. (0-9999)
LlxxxxxA	As above, for current supplied to terminals 32-33

### 10.2 - LASTTRIP

Display of the function which caused the tripping of the relay plus values of the parameters at the moment of tripping. The last five events are recorded.  
The memory buffer is refreshed at each new relay tripping with a decreasing numbering (FIFO logic).

Display	Description
LastTr-x	Indication of the recorded event (x= 0 to 4) Example: Last event (LastTr -0) Last but one event (LastTr-1) etc...
xxXXXxx	Date : Day, Month, Year
xx:xx:xx	Hour : Hours, Minutes, Seconds
F:xxxxxx	Function which produced the event being displayed and faulty phase in case of phase current element's trip 1l, 2l, 3l.
Hlxx.xpU	Current of input 29-30 (HI) (valued recorded at the moment of tripping)
Llxx.xpU	Current of input 32-33 (LI) (valued recorded at the moment of tripping)

### 10.3 - TRIP NUM

Counters of the number of operations for each of the relay functions.  
The memory is non-volatile and can be cancelled only with a secret procedure.

Display	Description
1l    xxxx	Trip number of first earth fault time delayed element    [t1l].
2l    xxxx	Trip number of second earth fault time delayed element    [t2l].
3l    xxxx	Trip number of third earth fault time delayed element    [t3l].

## 11. READING OF PROGRAMMED SETTINGS AND RELAY'S CONFIGURATION

Enter the mode "SET DISP", select the menu "SETTINGS" or "F → RELAY", scroll information available in the menu by keys "+" or "-" .

SETTINGS= values of relay's operation parameters as programmed

F → RELAY= output relays associated to the different functions as programmed.



12. PROGRAMMING

The relay is supplied with the standard default programming used for factory test. [ Values here below reported in the " Display " column ].

All parameters can be modified as needed in the mode PROG and displayed in the mode SET DISP Local Programming by the front face key board is enabled only if no input current is detected (main switch open). Programming via the serial port is always enabled but a password is required to access the programming mode. The default password is the null string; in the standard application program for communication "MS-COM" it is also provided an emergency password which can be disclosed on request only.

As soon as programming is enabled, the Led PRG/IRF flashes and the alarm relay R5 is deenergized.. Enter MODE "PROG" and SELECT either "SETTING1" or "SETTING2" for programming of parameters or "F→RELAY" for programming of output relays configuration; enable programming by the indirect operation key PROG.

The key SELECT now scrolls the available parameters. By the key (+) , (-) the displayed values can be modified; to speed up parameter's variation press the key SELECT while "+" or "-" are pressed.

Press key "ENTER/RESET" to validate the set values.

12.1 - PROGRAMMING OF FUNCTIONS SETTINGS

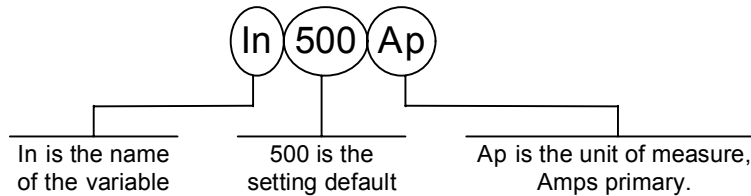

Mode PROG menu SETTINGS. (Production standard settings here under shown).

Display	Description	Setting Range	Step	Unit
xxxxxxx	Current date	DDMMYY	-	-
xx:xx:xx	Current time	HH:MM:SS	-	-
Fn 50 Hz	Mains frequency	50 - 60	10	Hz
HI 500Ap	Rated primary current of the C.T. supplying terminals 29-28(30)	1 - 9999	1	A
LI 500Ap	Rated primary current of the C.T. supplying terminals 32-31(33)	1 - 9999	1	A
F(1) D	Operation characteristic of the first earth fault element: (D) = Independent definite time (A) = IEC Inverse Time Curve type A (B) = IEC Very Inverse Time Curve type B (C) = IEC Extremely Inverse Time Curve type C (MI) = IEEE Moderate Inverse Curve (SI) = IEEE Short Inverse Curve (VI) = IEEE Very Inverse Curve (I) = IEEE Inverse Curve (EI) = IEEE Extremely Inverse Curve	D A B C MI SI VI I EI	-	-
1I 1.0LI	Trip level of first earth fault element (p.u. of the rated current of the C.T supplying the LI input) 1F50N	0.01 - 2 - Dis	0.01	LI
t1I 0.05s	Trip time delay of first earth fault element. In the inverse time operation [t1I] is the trip time delay at $I_0 = 10 \times [1I]$ . 1F51N	0.05 - 30	0.01	s
2I 1.0LI	Trip level of second earth fault element (p.u. of the rated current of the C.T supplying the LI input) 2F50N	0.01 - 2 - Dis	0.01	LI
t2I 0.05s	Trip time delay of the second earth fault element ( $I_0 \gg$ ) 2F51N	0.05 - 3	0.01	s
3I 1.0HI	Trip level of third earth fault element (p.u. of the rated current of the C.T supplying the HI input) 3F50N	0.5 - 10 - Dis	0.1	HI
t3I 0.02s	Trip time delay of the third earth fault element ( $I_0 \gg \gg$ ) 2F51N	0.02 - 3	0.01	s
tBF 0.05s	Time delay for Breaker Failure alarm	0.05 - 0.75	0.01	s
Tsyn Dis m	Synchronisation Time (Expected time interval between sync. pulses.)	5 - 60 - Dis	5-10 15-30 60-Dis	m
NodAd 1	Identification number for connection on serial communication bus	1 - 250	1	-

The setting Dis indicates that the function is deactivated.



12.2 - PROGRAMMING THE CONFIGURATION OF OUTPUT RELAYS

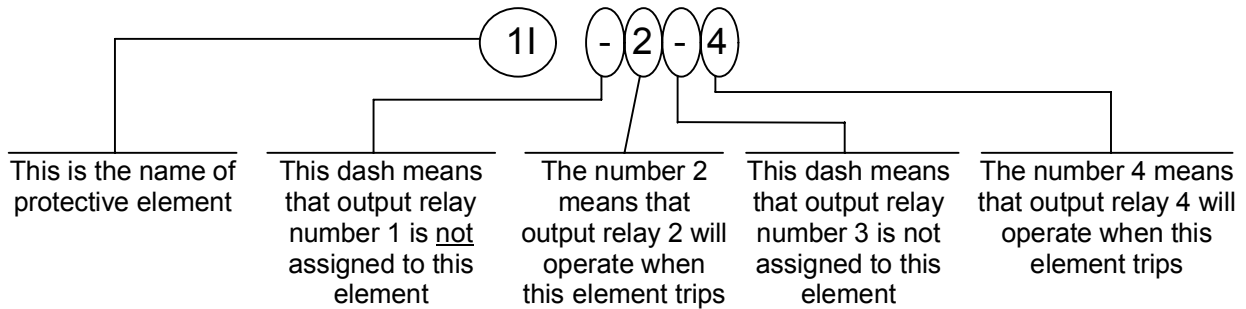

Mode PROG menu F→RELAY (Production standard settings here under shown).

The key "+" operates as cursor; it moves through the digits corresponding to the four programmable relays in the sequence 1,2,3,4,(1= relay R1, etc.) and makes start flashing the information actually present in the digit. The information present in the digit can be either the number of the relay (if this was already associated to the function actually on programming) or a dot (-) if the relay was not yet addressed. The key "-" changes the existing status from the dot to the relay number or viceversa.

Display	Description
1I ----	Instantaneous element of first earth fault element operates relay R1,R2,R3,R4. 1F50N
t1I 1---	As above, time delayed element. 1F51N
2I ----	Instantaneous element of second earth fault element operates relay R1,R2,R3,R4. 2F50N
t2I 1---	As above, time delayed element. 2F51N
3I ----	Instantaneous of the third earth fault element operates relay R1,R2,R3,R4. 3F50N
t3I -2--	As above, time delayed element. 3F51N
tBF ---4	Breaker failure alarm operates relay R1,R2,R3,R4.
tFRes: A	The reset after tripping of the relays associated to the time delayed elements can take place: (A) automatically when current drops below the trip level. (M) manually by the operation of the "ENTER/RESET" key.
B2 1I,2I	The input (B2) for blocking the operation of the time delayed elements relevant to input terminals LI (1I, 2I) can act on the function (1I) only or (2I) only, or on both
B3 3I	The input (B3) for blocking the operation of the time delayed element relevant to input terminals HI (3I) can bloc on the function (3I) or not(--).
tB2 2tBF	The blocking of the elements 1I, 2I can be programmed so that it lasts as long the blocking input signal is present (tB2 = Dis) or so that, even with the blocking input still present, it only lasts for the set trip time delay of the function plus an additional time 2xtBF (tB2 = 2xtBF).
tB3 2tBF	As above, for the earth fault elements (tB3 = Dis) or (tB3 = 2tBF).

### 13. MANUAL TEST OPERATION

#### 13.1 - Mode "TESTPROG" subprogram "W/O TRIP"

Operation of the yellow key activates a complete test of the electronics and the process routines. All the leds are lit-on and the display shows (TEST RUN). If the test routine is successfully completed the display switches-over to the default reading (xx:xx:xx).

If an internal fault is detected, the display shows the fault identification code and the relay R5 is deenergized. This test can be carried-out even during the operation of the relay without affecting the relay tripping in case a fault takes place during the test itself.

#### 13.2 - Mode "TESTPROG" subprogram "WithTRIP"

Access to this program is enabled only if the current detected is zero (breaker open).

Pressing the yellow key the display shows "TEST RUN?". A second operation of the yellow key starts a complete test which also includes the activation of all the output relays.

The display shows (TEST RUN) with the same procedure as for the test with W/O TRIP.

Every 15 min during the normal operation the relay automatically initiates an auto test procedure (duration  $\leq 10$ ms). If any internal fault is detected during the auto test, the relay R5 is deenergized, the relevant led is activated and the fault code is displayed.

**WARNING**

Running the WithTRIP test will operate all of the output relays. Care must be taken to ensure that no unexpected or harmful equipment operations will occur as a result of running this test.

It is generally recommended that this test be run only in a bench test environment or after all dangerous output connections are removed.

### 14. MAINTENANCE

No maintenance is required. Periodically a functional check-out can be made with the test procedures described under MANUAL TEST chapter. In case of malfunctioning please contact Microelettrica Scientifica Service or the local Authorised Dealer mentioning the relay's Serial No reported in the label on relays enclosure.

**WARNING**

In case of Internal Relay Fault detection, proceed as here-below indicated :

- If the error message displayed is one of the following "DSP Err", "ALU Err", "KBD Err", "ADC Err", switch off power supply and switch-on again. If the message does not disappear send the relay to Microelettrica Scientifica (or its local dealer) for repair.
- If the error message displayed is "E2P Err", try to program any parameter and then run "W/OTRIP".
- If message disappear please check all the parameters.
- If message remains send the relay to Microelettrica Scientifica (or its local dealer) for repair.

### 15. POWER FREQUENCY INSULATION TEST

Every relay individually undergoes a factory insulation test according to IEC255-5 standard at 2 kV, 50 Hz 1min. Insulation test should not be repeated as it unusefully stresses the dielectrics.

When doing the insulation test, the terminals relevant to serial output must always be short circuited to ground. When relays are mounted in switchboards or relay boards that have to undergo the insulation tests, the relay modules must be drawn-out of their enclosures and the test must only include the fixed part of the relay with its terminals and the relevant connections.

This is extremely important as discharges eventually taking place in other parts or components of the board can severely damage the relays or cause damages, not immediately evident to the electronic components.

**16. ELECTRICAL CHARACTERISTICS**

APPROVAL: CE

REFERENCE STANDARDS IEC 60255 - EN50263 - CE Directive - EN/IEC61000 - IEEE C37

<input type="checkbox"/> Dielectric test voltage	IEC 60255-5	2kV, 50/60Hz, 1 min.
<input type="checkbox"/> Impulse test voltage	IEC 60255-5	5kV (c.m.), 2kV (d.m.) – 1,2/50µs
<input type="checkbox"/> Insulation resistance	> 100MΩ	

Environmental Std. Ref. (IEC 68-2-1 - 68-2-2 - 68-2-33)

<input type="checkbox"/> Operation ambient temperature	-10°C / +55°C
<input type="checkbox"/> Storage temperature	-25°C / +70°C
<input type="checkbox"/> Humidity	IEC68-2-3 RH 93% Without Condensing AT 40°C

CE EMC Compatibility (EN50081-2 - EN50082-2 - EN50263)

<input type="checkbox"/> Electromagnetic emission	EN55022	industrial environment
<input type="checkbox"/> Radiated electromagnetic field immunity test	IEC61000-4-3 level 3 ENV50204	80-1000MHz 10V/m 900MHz/200Hz 10V/m
<input type="checkbox"/> Conducted disturbances immunity test	IEC61000-4-6 level 3	0.15-80MHz 10V
<input type="checkbox"/> Electrostatic discharge test	IEC61000-4-2 level 4	6kV contact / 8kV air
<input type="checkbox"/> Power frequency magnetic test	IEC61000-4-8	1000A/m 50/60Hz
<input type="checkbox"/> Pulse magnetic field	IEC61000-4-9	1000A/m, 8/20µs
<input type="checkbox"/> Damped oscillatory magnetic field	IEC61000-4-10	100A/m, 0.1-1MHz
<input type="checkbox"/> Electrical fast transient/burst	IEC61000-4-4 level 3	2kV, 5kHz
<input type="checkbox"/> HF disturbance test with damped oscillatory wave (1MHz burst test)	IEC60255-22-1 class 3	400pps, 2,5kV (m.c.), 1kV (d.m.)
<input type="checkbox"/> Oscillatory waves (Ring waves)	IEC61000-4-12 level 4	4kV(c.m.), 2kV(d.m.)
<input type="checkbox"/> Surge immunity test	IEC61000-4-5 level 4	2kV(c.m.), 1kV(d.m.)
<input type="checkbox"/> Voltage interruptions	IEC60255-4-11	
<input type="checkbox"/> Resistance to vibration and shocks	IEC60255-21-1 - IEC60255-21-2	10-500Hz 1g

CHARACTERISTICS

<input type="checkbox"/> Accuracy at reference value of influencing factors	0,2% On for measure 2% +/- 10ms for times
<input type="checkbox"/> Rated Current	In = 1 or 5A
<input type="checkbox"/> Current overload	200 A for 1 sec; 10A continuous
<input type="checkbox"/> Burden on current inputs	LI : 0.01VA at In = 1A; 0.2VA at In = 5A HI : 0.03VA at In = 1A ; 0.2VA at In = 5A
<input type="checkbox"/> Average power supply consumption	8.5 VA
<input type="checkbox"/> Output relays	rating 5 A; Vn = 380 V A.C. resistive switching = 1100W (380V max) make = 30 A (peak) 0,5 sec. break = 0.3 A, 110 Vcc, L/R = 40 ms (100.000 op.)

Microelettrica Scientifica S.p.A. - 20089 Rozzano (MI) - Italy - Via Alberelle, 56/68

Tel. (##39) 02 575731 - Fax (##39) 02 57510940

<http://www.microelettrica.com> e-mail : [ute@microelettrica.com](mailto:ute@microelettrica.com)

The performances and the characteristics reported in this manual are not binding and can modified at any moment without notice



17. CONNECTION DIAGRAM (SCE1693 Rev.0 Standard Output)

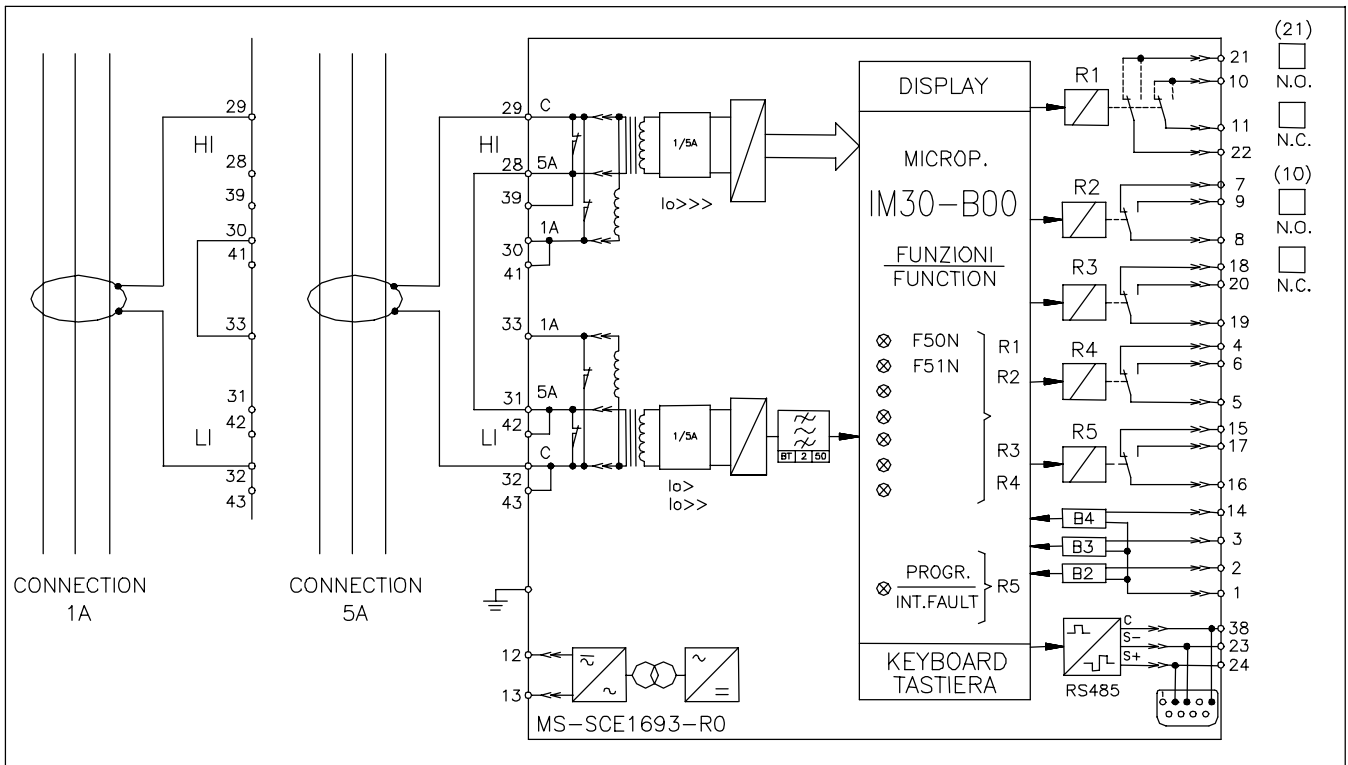

18. WIRING THE SERIAL COMMUNICATION BUS (SCE1309 Rev.0)

CONNECTION TO RS485

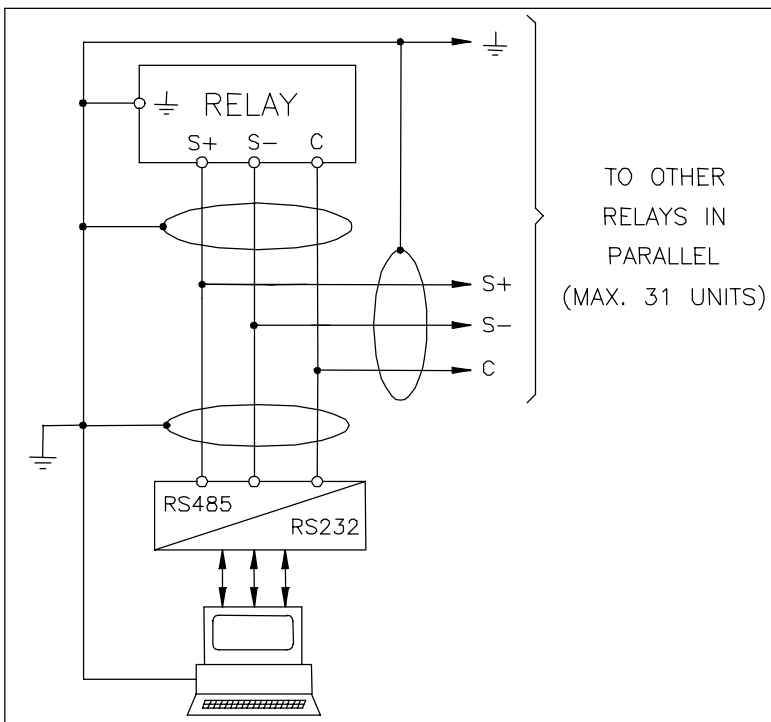

FIBER OPTIC CONNECTION

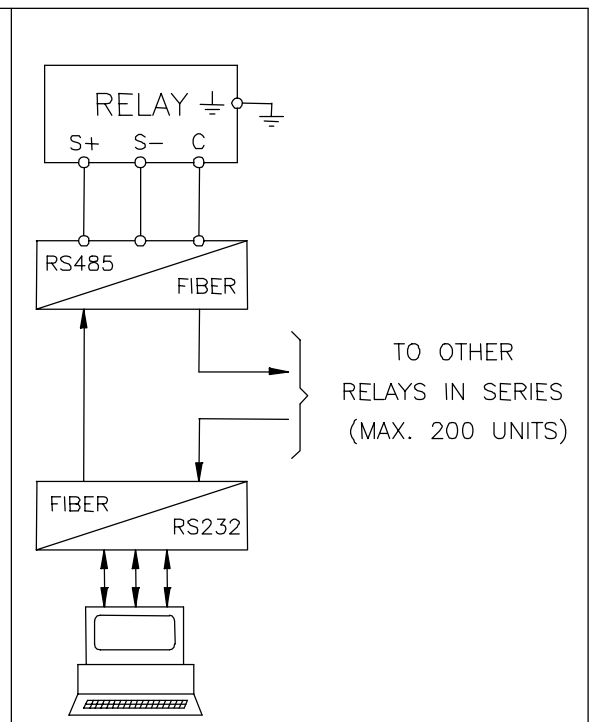



19. TIME CURRENT CURVES IEC (TU0388 Rev.0 1/2)

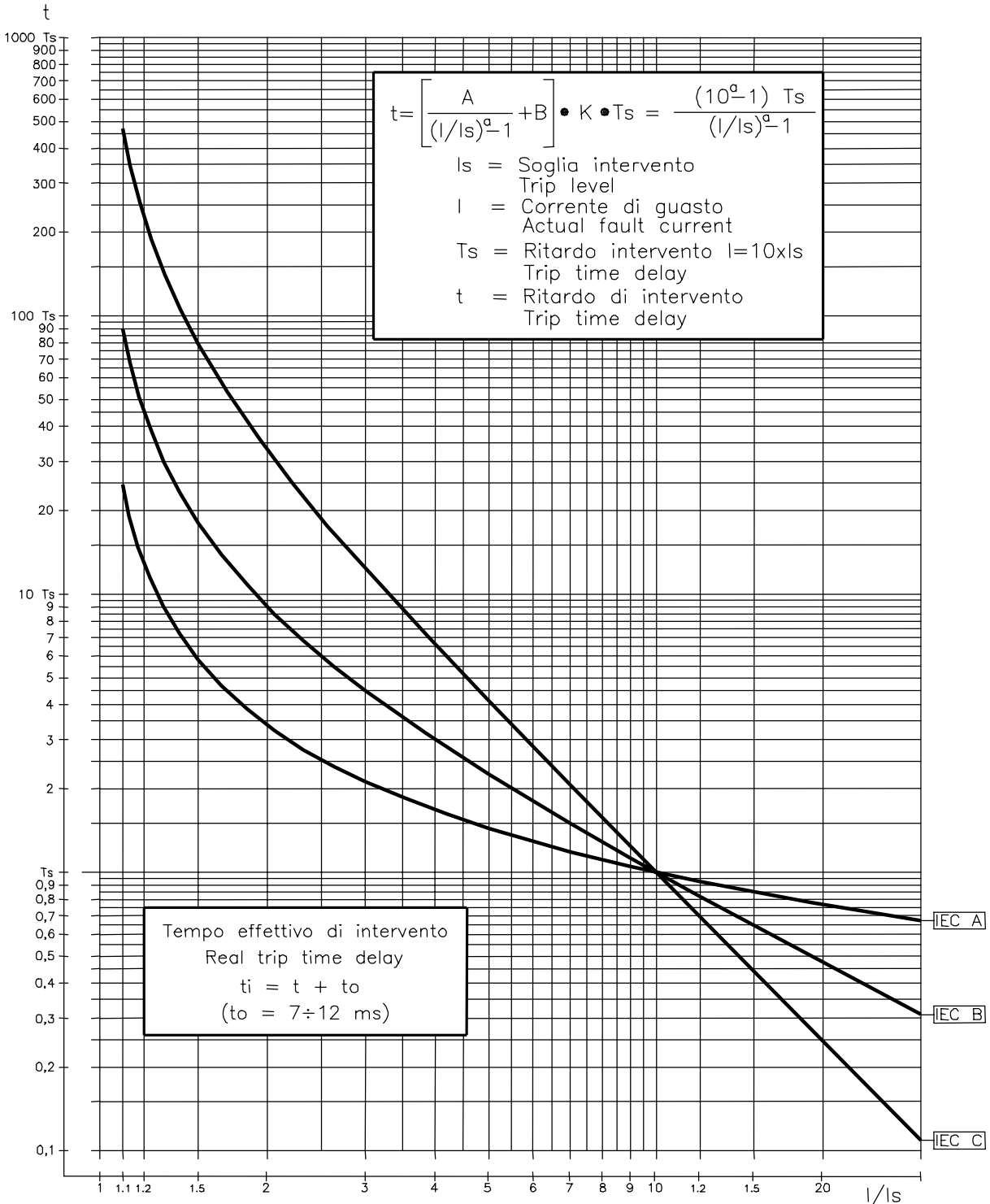

Curve Type	A	B	K	a
IEC A	0.14	0	0.336632	0.02
IEC B	13.5	0	0.666667	1
IEC C	80	0	1.2375	2

$$F51N \left\{ \begin{array}{l} I_s = 1I = (0.01 - 2)LI \\ T_s = t1I = (0.05 - 30)s \end{array} \right.$$



20. TIME CURRENT CURVES IEEE (TU0388 Rev.0 2/2)

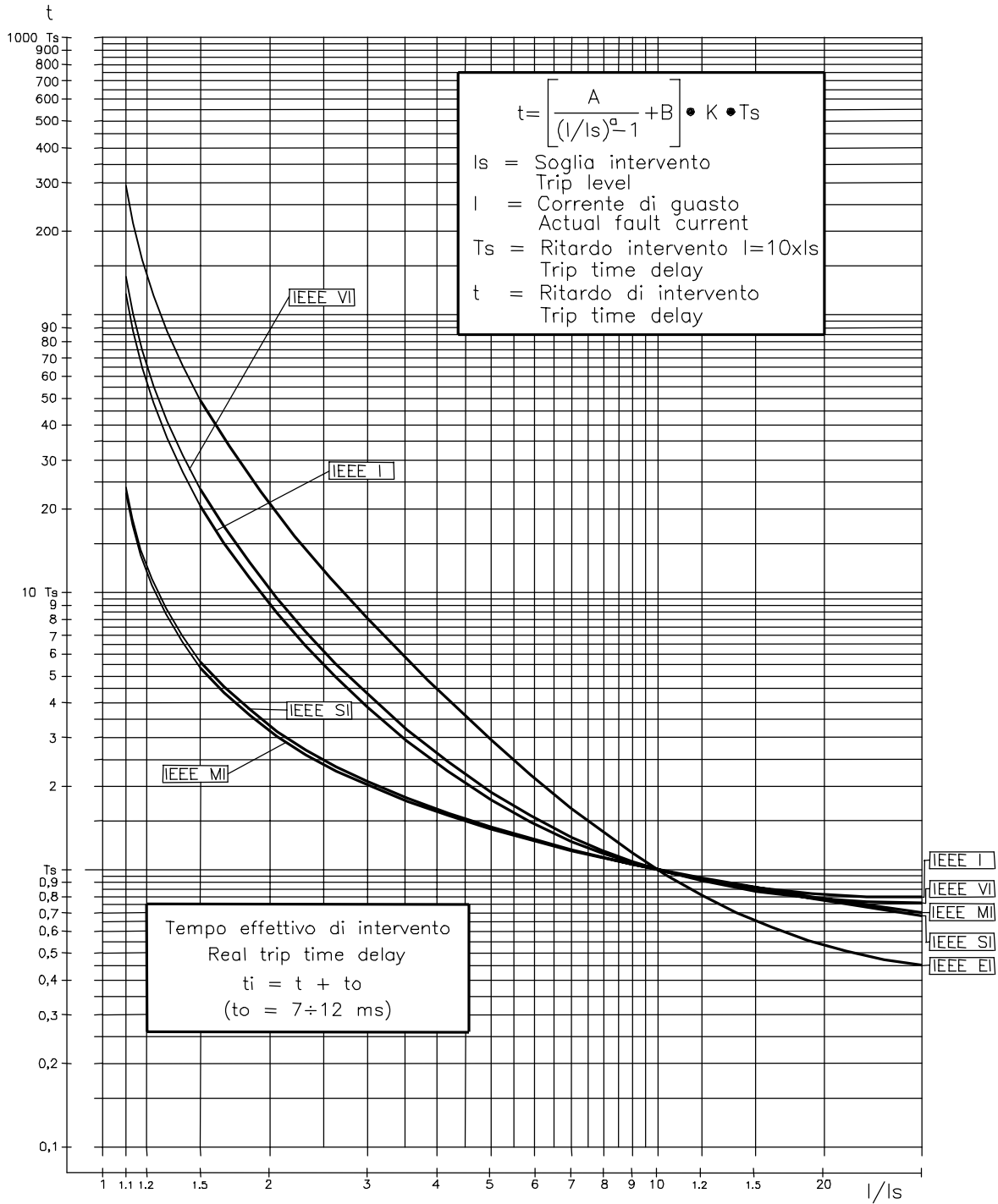

Curve Type	A	B	K	a
MI= IEEE Moderate Inv.	0.0104	0.0226	4.110608	0.02
SI= IEEE Short Inv.	0.00342	0.00262	13.30009	0.02
VI= IEEE Very Inv.	3.88	0.0963	7.380514	2
I= IEEE Inverse	5.95	0.18	4.164914	2
EI= IEEE Extremely Inv.	5.67	0.0352	10.814	2





22. MOUNTING

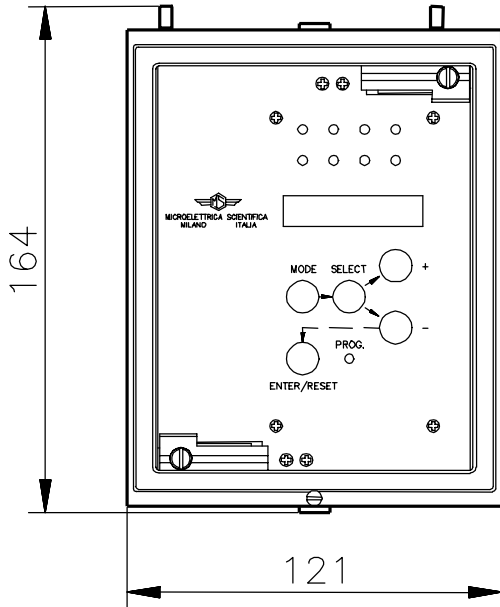

PANEL CUT-OUT 113x142 (LxH)

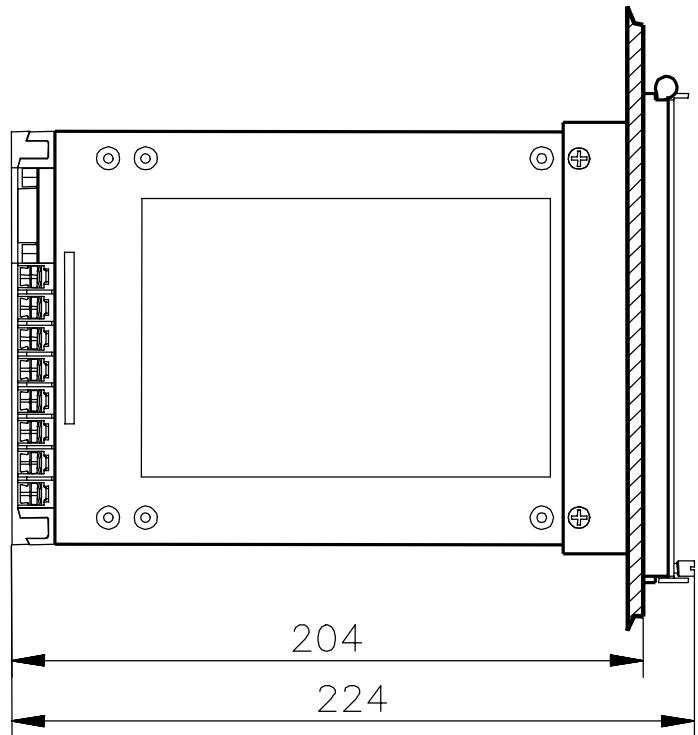

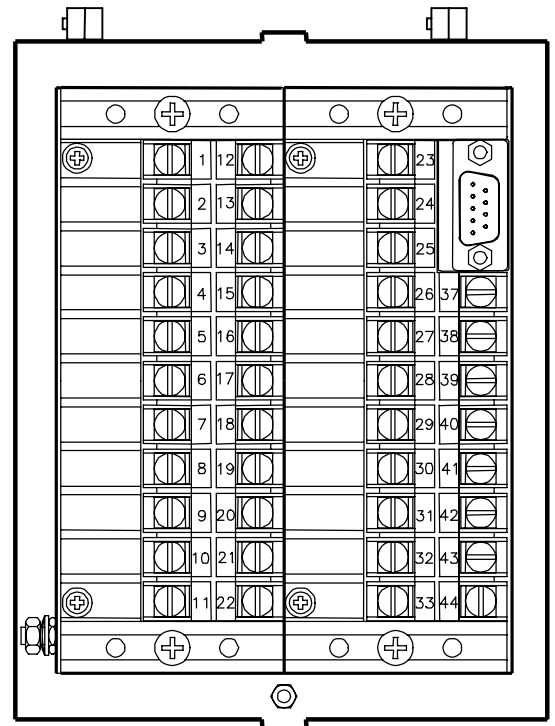
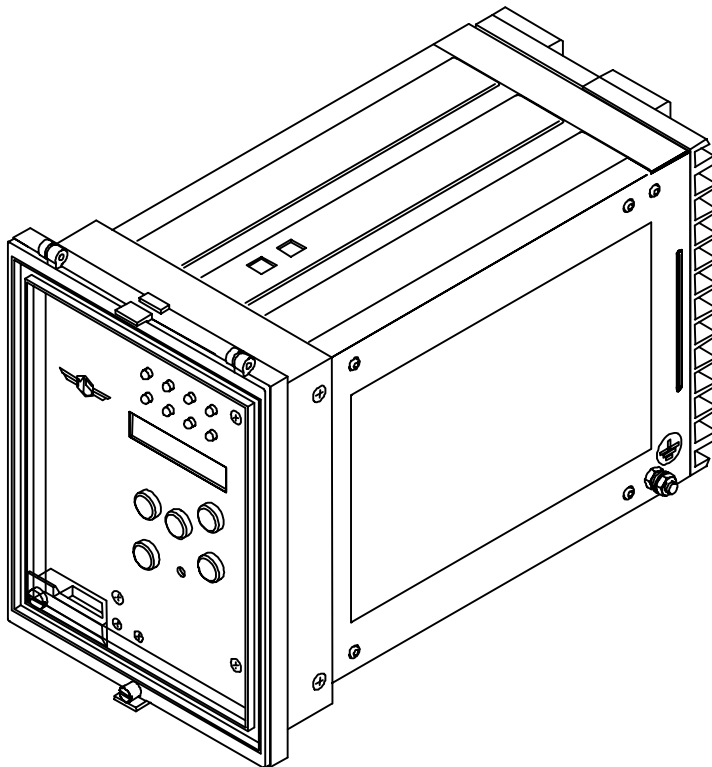

View of Rear Terminal Connection



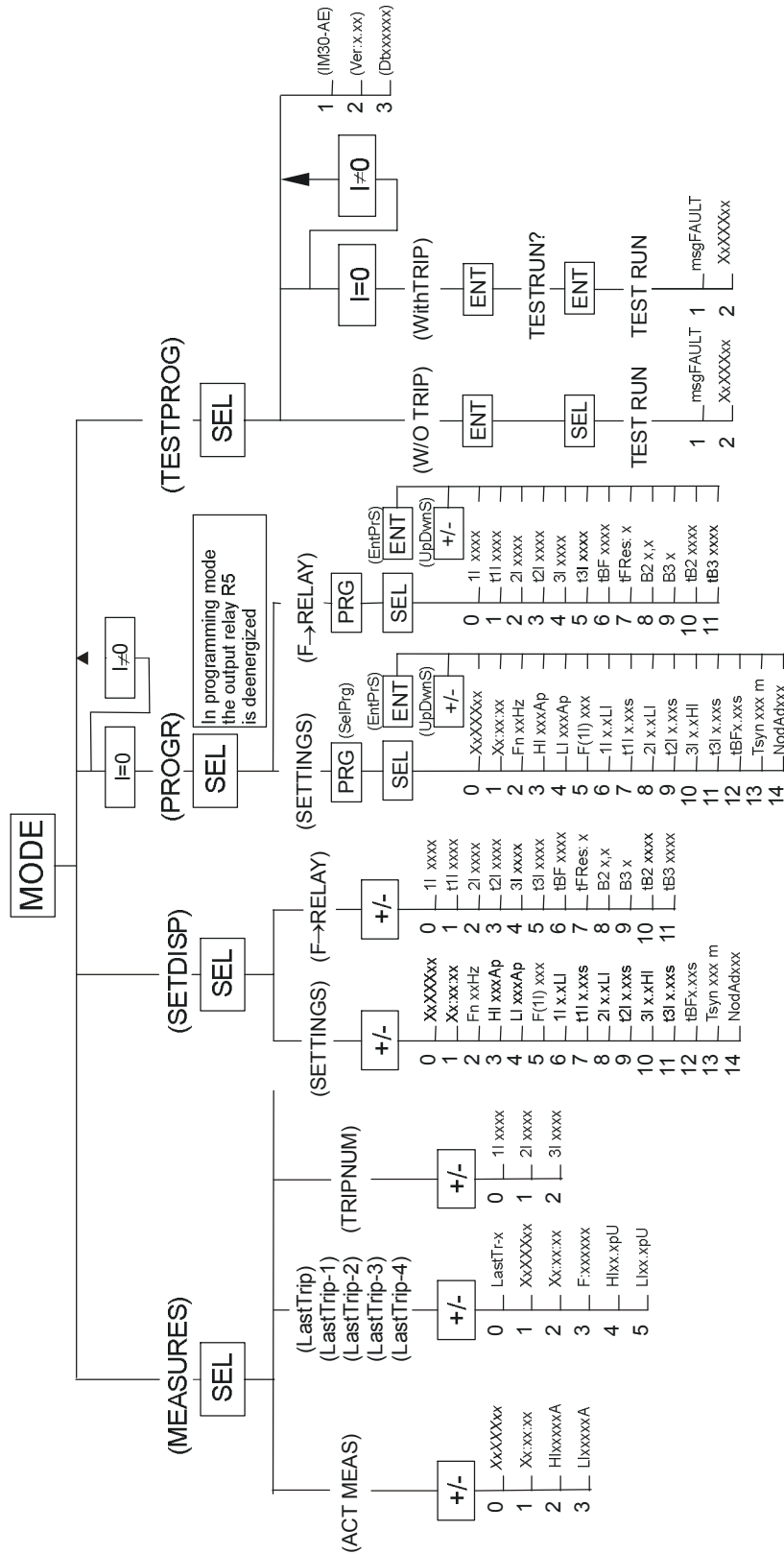

23. KEYBOARD OPERATIONAL DIAGRAM



	IM30-B00	Doc. N° MO-0132-ING
		Rev. 1
		Date 20.02.2003

#### 24. SETTING'S FORM

Relay Type	IM30-B00	Station :		Circuit :	
Date :	/ /	FW Version :		Relay Serial Number :	
Power Supply	<input type="checkbox"/> 24V(-20%) / 110V(+15%) a.c.    24V(-20%) / 125V(+20%) d.c. <input type="checkbox"/> 80V(-20%) / 220V(+15%) a.c.    90V(-20%) / 250V(+20%) d.c.	Rated Current :	<input type="checkbox"/> 1A	<input type="checkbox"/> 5A	

#### RELAY PROGRAMMING

Variable	Description	Setting Range	Default Setting	Actual Setting	Test Result
xxxxxxx	Current date	DDMMYY	-	Random	
xx:xx:xx	Current time	HH:MM:SS	-	Random	
Fn	Mains frequency	50 - 60	Hz	50	
HI	Rated primary current of the C.T. supplying terminals 29-28(30)	1 - 9999	Ap	500	
LI	Rated primary current of the C.T. supplying terminals 32-31(33)	1 - 9999	Ap	500	
F(1)	Operation characteristic of the first earth fault element	D A B C M I S I V I E I	-	D	
1I	Trip level of first earth fault element	0.01 - 2 - Dis	LI	1.0	
1I1	Trip time delay of first earth fault element.	0.05 - 30	s	0.05	
2I	Trip level of second earth fault element	0.01 - 2 - Dis	LI	1.0	
2I1	Trip time delay of the second earth fault element	0.05 - 3	s	0.05	
3I	Trip level of third earth fault element	0.5 - 10 - Dis	HI	0.1	
3I1	Trip time delay of the third earth fault element	0.02 - 3	s	0.02	
tBF	Time delay for Breaker Failure alarm	0.05 - 0.75	s	0.05	
Tsyn	Synchronisation Time Expected time interval between sync. pulses.	5 - 60 - Dis	m	Dis	
NodAd	Identification number for connection on serial communication bus	1 - 250	-	1	

#### CONFIGURATION OF OUTPUT RELAYS

Default Setting		Actual Setting		Description	Protect. Element		Output Relays	
Protect. Element	Output Relays	Protect. Element	Output Relays		Protect. Element	Output Relays	Protect. Element	Output Relays
1I	1 - - -			Instantaneous element of first earth fault element	1I			
1I1	- - - -			As above, time delayed element.	1I1			
2I	1 - - -			Instantaneous element of second earth fault element	2I			
2I1	- - - -			As above, time delayed element.	2I1			
3I	- - - -			Instantaneous of the third earth fault element	3I			
3I1	- 2 - -			As above, time delayed element.	3I1			
tBF	- - - 4			Breaker failure alarm	tBF			
tFRes:	A			The reset after tripping of the relays associated to the time delayed elements can take place: (A) automatically (M) manually	tFRes:			
B2	1I,2I			The input (B2) for blocking the operation of the time delayed elements relevant to input terminals LI	B2			
B3	3I			The input (B3) for blocking the operation of the time delayed elements relevant to input terminals HI	B3			
tB2	2tBF			The blocking of the elements 1I, 2I	tB2			
tB3	2tBF			As above, for the earth fault elements	tB3			

Commissioning Engineer : \_\_\_\_\_ Date : \_\_\_\_\_

Customer Witness : \_\_\_\_\_ Date : \_\_\_\_\_