

DIGITAL-MULTIFUNCTION  
GENERATOR DIFFERENTIAL  
PROTECTION RELAY  
TYPE  
MD32-G  
OPERATION MANUAL

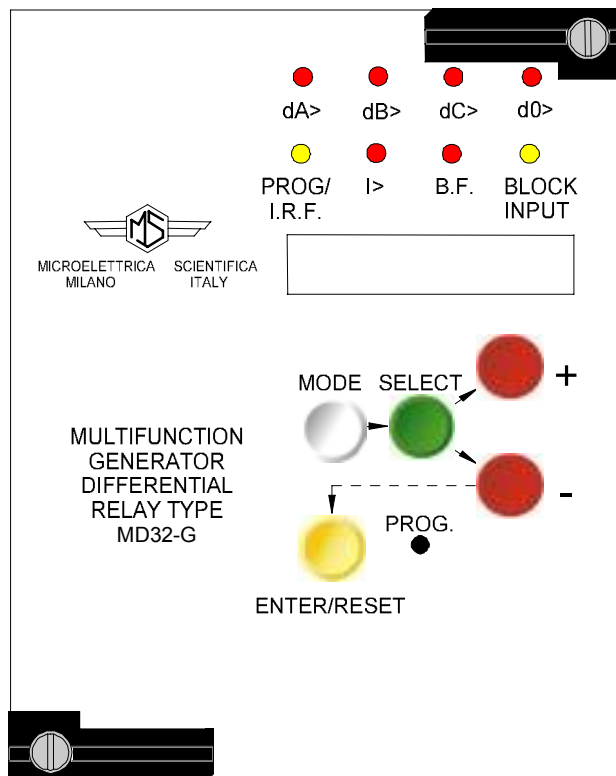



INDEX

|       |  |    |
|-------|--|----|
| 1     | General utilization and commissioning directions         | 3  |
| 1.1   | Storage and transportation                               | 3  |
| 1.2   | Installation   | 3  |
| 1.3   | Electrical connection                                    | 3  |
| 1.4   | Measuring inputs and power supply                        | 3  |
| 1.5   | Outputs loading  | 3  |
| 1.6   | Protection earthing                                      | 3  |
| 1.7   | Setting and calibration                                  | 3  |
| 1.8   | Safety protection  | 3  |
| 1.9   | Handling   | 3  |
| 1.10  | Maintenance  | 4  |
| 1.11  | Fault detection and repair                               | 4  |
| 2     | General characteristics and operation                    | 4  |
| 2.1   | Power supply   | 4  |
| 2.2   | Differential protection F87TG                            | 5  |
| 2.2.1 | Second Harmonic Restraint                                | 6  |
| 2.3   | Stator Overcurrent Protection F51G                       | 6  |
| 2.4   | Breaker Failure Protection                               | 6  |
| 2.5   | Earth Fault protection F87N/F51G                         | 7  |
| 2.6   | Functions blocking                                       | 7  |
| 2.7   | Characteristics required for C.Ts.                       | 8  |
| 2.8   | Value of the stabilising resistor                        | 8  |
| 3     | Controls and measurements                                | 9  |
| 4     | Signalization  | 10 |
| 5     | Output relays  | 11 |
| 6     | Serial communication                                     | 11 |
| 7     | Oscillography records                                    | 12 |
| 8     | Digital inputs   | 12 |
| 9     | Test   | 12 |
| 10    | Keyboard and display operation                           | 13 |
| 11    | Reading of measurements and recorded parameters          | 14 |
| 11.1  | ACT. MEAS (Actual measure)                               | 14 |
| 11.2  | MAX VAL (Max val)  | 14 |
| 11.3  | LASTTRIP (Last trip)                                     | 15 |
| 11.4  | TRIP NUM (Trip number)                                   | 15 |
| 12    | Reading of programmed settings and relay's configuration | 15 |
| 13    | Programming  | 16 |
| 13.1  | Programming of functions settings                        | 16 |
| 13.2  | Programming the configuration of output relay            | 17 |
| 14    | Manual and automatic test operation                      | 18 |
| 14.1  | Mode "TEST PROG" subprogram "W/O TRIP"                   | 18 |
| 14.2  | Mode "TEST PROG" subprogram "WhitTRIP"                   | 18 |
| 15    | Maintenance  | 18 |
| 16    | Electrical characteristics                               | 19 |
| 17    | Connection diagram 87G + 87N                             | 20 |
| 17.1  | Connection diagram 87G + 64G                             | 20 |
| 18    | Wiring the serial communication bus                      | 19 |
| 19    | Change phase current rated input 1 or 5A                 | 21 |
| 20    | Direction for pcb's draw-out and plug-in                 | 22 |
| 20.1  | Draw-out   | 22 |
| 20.2  | Plug-in  | 22 |
| 21    | Mounting / Overall dimensions                            | 23 |
| 22    | Keyboard operational diagram                             | 24 |
| 23    | Setting's form   | 25 |



## 1. General utilization and commissioning directions

Always make reference to the specific description of the product and to the Manufacturer's instruction. Carefully observe the following warnings.

### 1.1 - STORAGE AND TRANSPORTATION,

must comply with the environmental conditions stated on the product's instruction or by the applicable IEC standards.

### 1.2 - INSTALLATION,

must be properly made and in compliance with the operational ambient conditions stated by the Manufacturer.

### 1.3 - ELECTRICAL CONNECTION,

must be made strictly according to the wiring diagram supplied with the Product, to its electrical characteristics and in compliance with the applicable standards particularly with reference to human safety.

### 1.4 - MEASURING INPUTS AND POWER SUPPLY,

carefully check that the value of input quantities and power supply voltage are proper and within the permissible variation limits.

### 1.5 - OUTPUTS LOADING,

must be compatible with their declared performance.

### 1.6 - PROTECTION EARTHING

When earthing is required, carefully check its effectiveness.

### 1.7 - SETTING AND CALIBRATION

Carefully check the proper setting of the different functions according to the configuration of the protected system, the safety regulations and the co-ordination with other equipment.

### 1.8 - SAFETY PROTECTION

Carefully check that all safety means are correctly mounted, apply proper seals where required and periodically check their integrity.

### 1.9 - HANDLING

Notwithstanding the highest practicable protection means used in designing M.S. electronic circuits, the electronic components and semiconductor devices mounted on the modules can be seriously damaged by electrostatic voltage discharge which can be experienced when handling the modules. The damage caused by electrostatic discharge may not be immediately apparent but the design reliability and the long life of the product will have been reduced. The electronic circuits reduced by M.S. are completely safe from electrostatic discharge (8 KV IEC 255.22.2) when housed in their case; withdrawing the modules without proper cautions expose them to the risk of damage.



- a. Before removing a module, ensure that you are at the same electrostatic potential as the equipment by touching the case.
- b. Handle the module by its front-plate, frame, or edges of the printed circuit board. Avoid touching the electronic components, printed circuit tracks or connectors.
- c. Do not pass the module to any person without first ensuring that you are both at the same electrostatic potential. Shaking hands achieves equipotential.
- d. Place the module on an antistatic surface, or on a conducting surface which is at the same potential as yourself.
- e. Store or transport the module in a conductive bag.

More information on safe working procedures for all electronic equipment can be found in BS5783 and IEC 147-OF.

### 1.10 - MAINTENANCE

Make reference to the instruction manual of the Manufacturer ;maintenance must be carried-out by specially trained people and in strict conformity with the safety regulations.

### 1.11 - FAULT DETECTION AND REPAIR

Internal calibrations and components should not be altered or replaced. For repair please ask the Manufacturer or its authorised Dealers.

Misapplication of the above warnings and instruction relieves the Manufacturer of any liability.

## 2. GENERAL CHARACTERISTICS AND OPERATION

Input currents from system's CT.s are supplied to two internal sets of 3 CT.s

An additional CT is used either for Restricted Earth Fault protection or for Stator Earth Fault current protection (see connection diagrams).

Input rated current can be set to 1 of 5A by 7 dip-switches provided on relay's card.

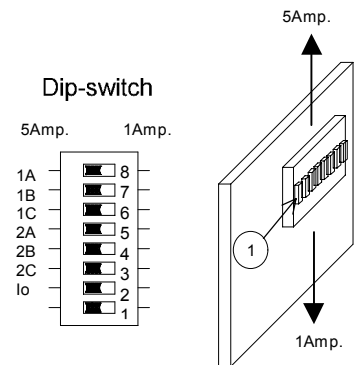

### 2.1- POWER SUPPLY

The relay can be fitted with two different types of power supply module :

- |                             |                             |
|-----------------------------|-----------------------------|
| a) - {                      | {                           |
| 24V(-20%) / 110V(+15%) a.c. | 80V(-20%) / 220V(+15%) a.c. |
| 24V(-20%) / 125V(+20%) d.c. | 90V(-20%) / 250V(+20%) d.c. |

Before energising the unit check that supply voltage is within the allowed limits.



2.2 - Differential Protection F87G

The relay performs a percentage biased differential protection of generator or rotating machinery:

- Two or three phase internal faults
- Restricted Earth Fault
- Earth Fault in low-impedance or directly earthed generators.

For each phase the relay measures :

- The system frequency component of the value of the vector difference between the currents at the two winding sides

$$d_x = |\bar{I}_{1x} - \bar{I}_{2x}| \quad x = A, B, C$$

- The Generator "Through current" 
$$I_{r_x} = \frac{|\bar{I}_{1_x}| + |\bar{I}_{2_x}|}{2}$$

The operation is based on the comparison of above measurements with the following programmable levels :

- Basic minimum differential pick-up level :  $d \geq (0.02 - 0.2)I_n$ , step  $0.01I_n$
- Percent bias in the zone  $0.5 < \frac{I_R}{I_n} < P$  :  $1R\% = (2-20)\%$ , step  $1\%$
- Percent bias in the zone  $\frac{I_R}{I_n} > P$  :  $2R\% = (5-50)\%$ , step  $1\%$
- Point of bias slope chagement :  $P = (1.00 - 3.00)$

To compensate the differential current produced by errors or saturation of the CTs, the actual differential current minimum pick-up level  $I_d$  is dynamically adjusted in function of the actual Through Current  $I_r$  depending on the set percent bias levels  $1R\%$ ,  $2R\%$ .

Fig.1

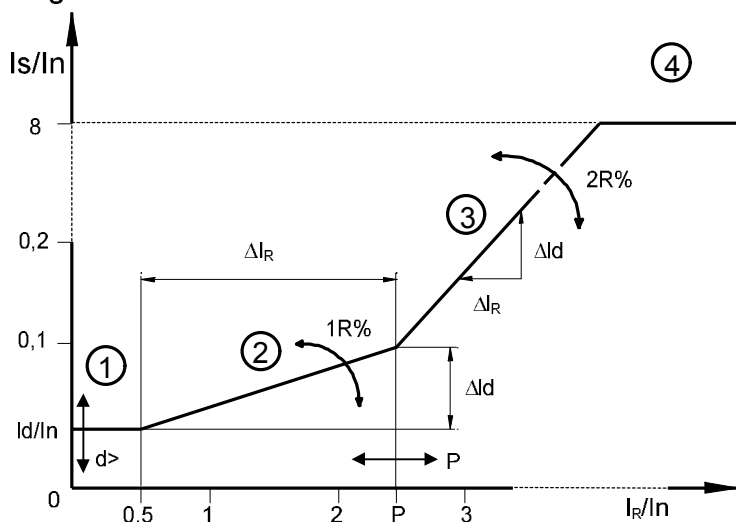

$$R\% = 100 \frac{\Delta I_d}{\Delta I_R}$$

- ①  $\frac{I_s}{I_n} = \frac{I_d}{I_n}$
- ②  $\frac{I_s}{I_n} = \frac{I_d}{I_n} + \left(\frac{I_R}{I_n} - 0,5\right) \cdot \frac{1R\%}{100}$
- ③  $\frac{I_s}{I_n} = \frac{I_d}{I_n} + \frac{(P-0,5)1R\%}{100} + \left(\frac{I_R}{I_n} - P\right) \frac{2R\%}{100}$
- ④  $\frac{I_s}{I_n} \cong 8$

$I_s$ = Effective relay's operation differential current  
 $I_d$ = Relay set differential current       $I_R$ = Relay's through current

The low set differential element operates instantaneously (less than 30ms) when the System frequency component of measured differential current of any phase exceeds the actual pick-up level  $I_s$ .



2.2.1 – Second Harmonic Restraint

Whenever the ratio of the second harmonic component to the system frequency component of the differential current of any phase exceeds the set level  $2H = (0.10-1.00)$ , the operation of the differential protection element is blocked.

2.3 - Stator Overcurrent Protection F51G

Relays measures the R.M.S. value of the phase currents.

- Minimum pick-up level :  $I > = (0.5-10)I_n$ , step  $0.01I_n$
- Trip time delay (Independent Definite time) :  $tI > = (0.05-9.99)s$ , step  $0.01s$

2.4 - Breaker Failure Protection

- $t_{BF} = (0.05-1.00)s$ , step  $0.01s$

If after the time  $t_{BF}$  from tripping of one function ( $d >$ ,  $I >$ ,  $do >$ ) the tripping cause is not removed, a proper output relay is energized to operate the second opening circuit of the Circuit Breaker or a back-up breaker.

It is possible to select which protection element controls the Breaker Failure function by programming the variable:

- $BF = d, I, do$

any combination is possible

|      |   |   |    |
|------|---|---|----|
| BF = | - | - | -  |
| BF = | d | - | -  |
| BF = | - | I | -  |
| BF = | - | - | do |
| BF = | d | I | -  |
| BF = | d | - | do |
| BF = | d | I | do |
| BF = | - | I | do |



2.5 - Earth Fault protection F87N/F51G

The relays measures the system frequency component only of the current feeding the input terminals 32-33

Depending upon connection this element can perform:

- ❑ Restricted Earth Fault Protection (87N)
- ❑ Neutral current protection (stator earth fault 64G).

The adjustable variables are :

- ❑ Minimum pick-up level :  $do > = (0.01 - 1)I_{on}$ , step 0.01  
( $I_{on}$  = Rated current of CT feeding input terminals 32-33)
- ❑ Instantaneous element :  $t \leq 30ms$
- ❑ Time delayed element :  $t_{do} = (0.05 - 9.99)s$ , step 0.01  
(Same trip level  $do >$  as the instantaneous element)

2.6 - Functions Blocking

Any function can be permanently deactivated setting to Dis the relevant variable, or temporarily blocked via the digital input B1

The operation of the blocking input B1 can be programmed to block (when activated) any of the relay functions by programming the variable B1.

- ❑  $B1 = d >, I >, do$

any combination is possible :

- B1 = - - -
- B1 = d > - -
- B1 = d > - -
- B1 = - I > -
- B1 = - - do
- B1 = d > I > -
- B1 = d > - do
- B1 = d > I > do
- B1 = - I > do



## 2.7 - CHARACTERISTICS REQUIRED FOR C.Ts.

### Relay burden on inputs at rated current

Phase inputs : PB = 0.01VA for C.T. 1A; PB = 0.2VA for C.T. 5A  
Neutral input : EB = 0.02VA for C.T. 1A; EB = 0.3VA for C.T. 5A

### C.T.'s requirements for phase differential protection

- Class 5P10 (or better)
- Minimum burden  $10 \times PB + (R_{CT} + R_L)$ , where:
  - $R_{CT}$  = Resistance of C.T. secondary winding
  - $R_L$  = Resistance of the loop lead between C.T. and relay plus resistance of the relay

### Additional requirements for R.E.F. protection

Minimum Knee-point voltage  $V_m = 2I_f(R_{CT} + R_L)$ , where  $I_f$  is the maximum expected Earth Fault current (C.T.'s secondary).

The effective minimum C.T.'s secondary current that produces relay pick-up is:

$I_{do} = [do >] - 4I_m$ , where:

$[do >]$  = Relay set current

$I_m$  = C.T. excitation current at  $V_m/2$ .

As a consequence to operate on a Fault Current  $I_{do}$  the relay setting current shall be

$[do >] \leq I_{do} - 4I_m$

## 2.8 - VALUE OF THE STABILISING RESISTOR

- The value of the externally mounted series resistor R is calculated as follows:

$$R = \frac{V_m/2 - EB/[do >]}{[do >]}$$

Continuously variable resistors are normally used:

- for 1A C.T.: (0-200)Ohm 100W rated

- for 5A C.T.: (0-50)Ohm 100W rated

In the unlikely case where the maximum prospective current  $I_f$  during internal Earth Fault can produce at C.T.'s terminals a voltage  $V_m = I_f(R + R_{TC} + R_L) > 2kV$  a non linear voltage limiting device Z is available



### 3. CONTROLS AND MEASUREMENTS

Five key buttons allow for local management of all relay's functions.

A 8-digit high brightness alphanumerical display shows the relevant readings (xxxxxxx) (see synoptic table fig. 1)

FIG.1

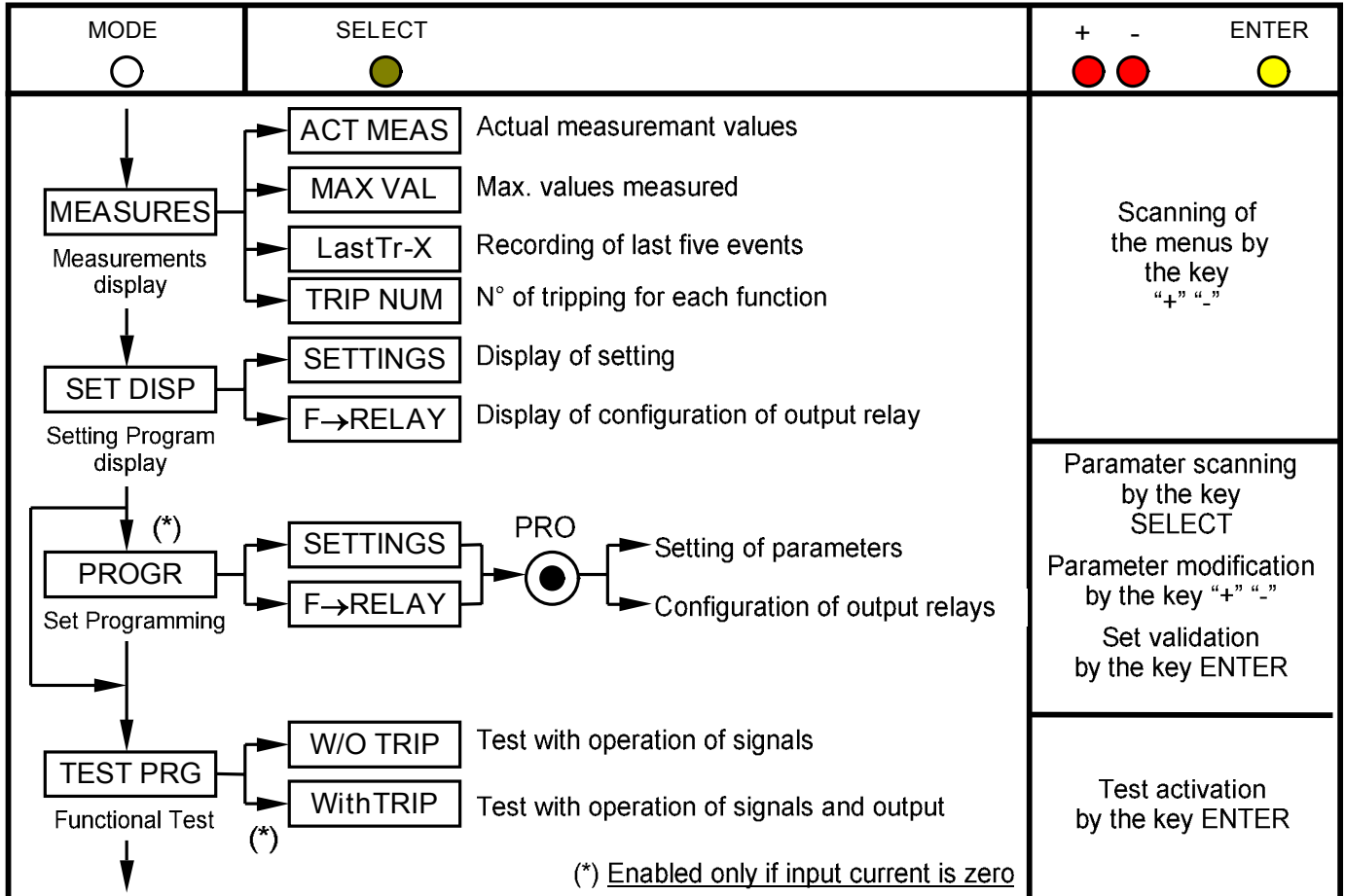

Pressing this button progressively selects between Measurements Display, Setting Display, Programming, and Test modes

The SELECT button chooses which category of values within the chosen mode to display

When in Program mode, this button stores the newly selected value. If not in Program mode and the relay has tripped, this button resets the relay and all output contacts. If not tripped, this button restores the default display.

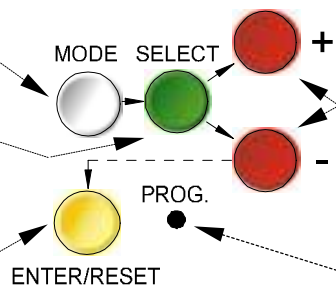

The + and - buttons are used to select the actual measurement or display desired when in Measurements Display or Settings Display modes. When in Program mode, these buttons increase or decrease the value of the displayed setting.

When in Program mode, and when all input currents are zero, pressing this recessed button places the relay into active programming mode, allowing any or all of the relay's settings to be altered.



#### 4. SIGNALIZATIONS

Eight signal leds (normally off) are provided:

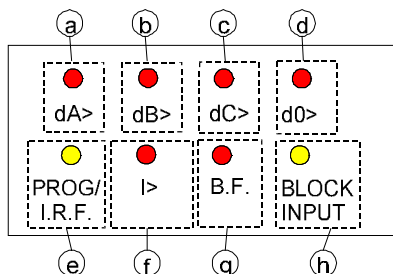

- |               |                 |  |
|---------------|-----------------|--|
| a) Red LED    | dA>             | <input type="checkbox"/> Illuminated on tripping of differential element phase A ( $I_{dA} \geq [dA]$ )  |
| b) Red LED    | dB>             | <input type="checkbox"/> Illuminated on tripping of differential element phase B ( $I_{dB} \geq [dB]$ )  |
| c) Red LED    | dC>             | <input type="checkbox"/> Illuminated on tripping of differential element phase C ( $I_{dC} \geq [dC]$ )  |
| d) Red LED    | d0>             | <input type="checkbox"/> Illuminated on tripping of the earth fault element ( $I_{o} > [d0]$ )   |
| e) Yellow LED | PROG/<br>I.R.F. | <input type="checkbox"/> Flashing during the programming of the parameters or in case of Internal Relay Fault  |
| f) Red LED    | I>              | <input type="checkbox"/> Flashing when the current in any phase exceeds the set level [ $I >$ ]<br><input type="checkbox"/> Illuminated on trip at the end of time delay tI> |
| g) Red LED    | B.F.            | <input type="checkbox"/> Illuminated on trip of the Breaker Failure function   |
| h) Yellow LED | BLOCK<br>INPUT  | <input type="checkbox"/> Flashing when digital input B1 is activated   |

The reset of the leds takes place as follows:

- From flashing to off, automatically when the lit-on cause disappears.
- From ON to OFF, by "ENTER/RESET" push button only if the tripping cause has disappeared.

In case of auxiliary power supply failure the status of the leds is recorded and reproduced when power supply is restored.



## 5. OUTPUT RELAYS

Five output relays are available (R1, R2, R3, R4, R5)

- The relays R1,R2,R3,R4 are normally deenergized (energized on trip): these output relays are user programmable and any of them can be associated to any of the MD32's functions.  
For function do> both instantaneous and time delayed elements are provided.  
The reset after tripping of the relays (when tripping cause has been cleared) can be programmed as Manual or Automatic (Variable RR=Man/Aut).  
FRes = Aut : Automatic Reset as soon as pick-up cause has been cleared.  
FRes = Man : Reset by ENT/RESET KEY on relay's front or via serial port
- The relay R5, normally energised, is not programmable and is deenergized on:
  - internal fault
  - power supply failure
  - during the programming

## 6. SERIAL COMMUNICATION

The relays fitted with the serial communication option can be connected via a cable bus or (with proper adapters) a fiber optic bus for interfacing with a Personal Computer (type IBM or compatible). All the operations which can be performed locally (for example reading of measured data and changing of relay's settings) are also possible via the serial communication interface. Furthermore the serial port allows the user to read the demand recording data. The unit has a RS232 / RS485 interface and can be connected either directly to a P.C. via a dedicated cable or to a RS485 serial bus, thus having many relays to exchange data with a single master P.C. using the same physical serial line. A RS485/232 converter is available on request. The communication protocol is MODBUS RTU (only functions 3, 4 and 16 are implemented). Each relay is identified by its programmable address code (NodeAd) and can be called from the P.C. A dedicated communication software (MSCOM) for Windows 95/98/NT4 SP3 (or later) is available. Please refer to the MSCOM instruction manual for more information Microelettrica Scientifica.



## 7. OSCILLOGRAPHY RECORDS

The relay continuously records in a buffer the samples of the seven input currents. The buffer contains samples for approximately 16 periods of each of the seven currents. Recording is stopped after approximately 8 periods after a trigger signal and the content of the buffer is stored into memory. Therefore in the memory are stored the wave forms for 8 cycles before and 8 cycles after the trigger instant. The trigger can be operated either internally on tripping of any function programmed  $d>$ ,  $l>$ ,  $lo>$ , or externally by activation of the digital input B3. Selection between the two modes is made by programming the variable TRG = EXT,  $d>$ ,  $l>$ ,  $do>$ . The last oscillography record is stored; a second record replaces the first.

## 8. DIGITAL INPUTS

Three inputs active when the relevant terminals are shorted are provided:

- B1 (terminals 1 - 2) : For function blocking
- B2 (terminals 1 - 3) : Not used
- B3 (terminals 1 - 14) : External trigger for oscillography records

## 9. TEST

Besides the normal "WATCHDOG" and "POWERFAIL" functions, a comprehensive program of self-test and self-diagnostic provides:

- Diagnostic and functional test, with checking of program routines and memory's content, run every time the aux. power is switched-on: the display shows the type of relay and its version number.
- Dynamic functional test run during normal operation every 15 min. (relay's operation is suspended for less than  $\leq 4ms.$ ). If any internal fault is detected, the display shows a fault message, the Led "PROG/IRF" illuminates and the relay R5 is deenergized.
- Complete test activated by the keyboard or via the communication bus either with or without tripping of the output relays.



10. KEYBOARD AND DISPLAY OPERATION

All controls can be operated from relay's front or via serial communication bus.  
The keyboard includes five hand operable buttons (MODE) - (SELECT) - (+) - (-) - (ENTER/RESET) plus one indirect operable key (PROG) (see synoptic table a fig.1):

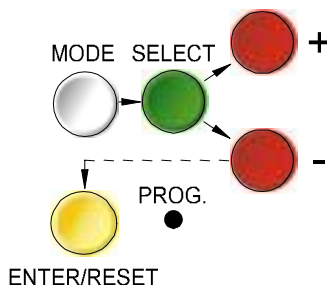

|                   |             |   |   |
|-------------------|-------------|---|---|
| a) - White key    | MODE        | : | when operated it enters one of the following operation modes indicated on the display :   |
|                   | MEASURES    | = | Reading of all the parameters measured and of those recorded in the memory  |
|                   | SET DISP    | = | Reading of the settings and of the configuration of the output relays as programmed.  |
|                   | PROG        | = | Access to the programming of the settings and of relay configuration.   |
|                   | TEST PROG   | = | Access to the manual test routines.   |
| b) - Green key    | SELECT      | : | When operated it selects one of the menus available in the actual operation MODE  |
| c) - Red key      | "+" AND "-" | : | When operated they allow to scroll the different information available in the menu entered by the key SELECT  |
| d) - Yellow key   | ENTER/RESET | : | It allows the validation of the programmed settings<br>- the actuation of test programs<br>- the forcing of the default display indication<br>- the reset of signal Leds. |
| e) - Indirect key | ●           | : | Enables access to the programming.  |

**11. READING OF MEASUREMENTS AND RECORDED PARAMETERS**

Enter the MODE "MEASURE", SELECT the menus "ACT.MEAS"-"MAX VAL"-"LASTTRIP"-"TRIP NUM", scroll available information by key "+" or "-" .

## 11.1 - ACT.MEAS

Actual values as measured during the normal operation. The values displayed are continuously updated.

| Display  | Description   |
|----------|---|
| dAxx.xxn | System frequency component of differential current of phase A : (0-99.99) per unit of rated phase input current |
| dBxx.xxn | As above phase B  |
| dCxx.xxn | As above phase C  |
| do x.xxn | As above residual current I <sub>o</sub>  |
| 1AxxxxxA | R.M.S. value of current of phase A of Generator's side 1: (0-99999) CT's primary Amp                            |
| 1BxxxxxA | As above phase B  |
| 1CxxxxxA | As above phase C  |
| 2AxxxxxA | R.M.S. value of current of phase A of Generator's side 2: (0-99999) CT's primary Amp                            |
| 2BxxxxxA | As above phase B  |
| 2CxxxxxA | As above phase C  |

## 11.2 - MAX VAL

Highest values recorded from Breaker closing, (updated any time the breaker closes).

| Display  | Description   |
|----------|---|
| dAxx.xxn | System frequency component of Differential current of phase A : (0-99.99) per unit of rated phase input current |
| dBxx.xxn | As above phase B  |
| dCxx.xxn | As above phase C  |
| dox.xxxn | As above residual current I <sub>o</sub>  |
| 1Axx.xn  | Current of phase A of side 1 input: (0-99.9) p.u. of phase input current  |
| 1Bxx.xn  | As above phase B of side 1 input  |
| 1Cxx.xn  | As above phase C of side 1 input  |
| 2Axx.xn  | Current of phase A of side 2 input: (0-99.9) p.u. of phase input current  |
| 2Bxx.xn  | As above phase B of side 2 input  |
| 2Cxx.xn  | As above phase C of side 2 input  |



## 11.3 - LASTTRIP

Display of the function which caused the tripping of the relay plus values of the parameters at the moment of tripping. The memory contains the records of the last five tripping (FIFO).

| Display  | Description   |
|----------|---|
| LastTr-x | Indication of the recorded event (x= 0 to 4)<br>Example: Last event (LastTr -0)<br>Last but one event (LastTr-1) etc... |
| Cau:xxxx | Function which produced the event being displayed: dA>, dB>, dC>, l>, do>   |
| dAxx.xxn | System frequency component of Differential current phase A  |
| dBxx.xxn | System frequency component of Differential current phase B  |
| dCxx.xxn | System frequency component of Differential current phase C  |
| dox.xxn  | System frequency component of Residual current I <sub>o</sub>   |
| 1Axxxxn  | Current phase A of side 1 input   |
| 1Bxxxxn  | As above phase B  |
| 1Cxxxxn  | As above phase C  |
| 2Axx.xn  | Current of phase A of side 2 input  |
| 2Bxx.xn  | As above phase B  |
| 2Cxx.xn  | As above phase C  |

## 11.4 - TRIP NUM

Counters of the number of operations for each of the relay's function.  
The memory is non-volatile and can be cancelled only with a secret procedure.

| Display  | Description                  |
|----------|------------------------------|
| dA> xxxx | Differential element phase A |
| dB> xxxx | Differential element phase B |
| dC> xxxx | Differential element phase C |
| do> xxxx | Earth fault element          |
| l> xxxx  | Overcurrent element          |

## 12. READING OF PROGRAMMED SETTINGS AND RELAY'S CONFIGURATION

Enter the mode "SET DISP", select the menu "SETTINGS" or "F→RELAY", scroll information available in the menu by keys "+" or "-".

SETTINGS= values of relay's operation parameters as programmed

F→RELAY= output relays associated to the different functions as programmed.



### 13. PROGRAMMING

The relay is supplied with the standard default programming used for factory test. [ Values here below reported in the " Display " column ].

All parameters can be modified as needed in the mode PROG and displayed in the mode SET DISP Local Programming by the front face key board is enabled only if no input current is detected (main switch open). Programming via the serial port is always enabled but a password is required to access the programming mode. The default password is the null string; in the standard application program for communication "MS-COM" it is also provided an emergency password which can be disclosed on request only.

As soon as programming is enabled, the Led PRG/IRF flashes and the reclosing lock-out relay R5 is deenergized. Enter MODE "PROG" and SELECT either "SETTINGS" for programming of parameters or "F→RELAY" for programming of output relays configuration; enable programming by the indirect operation key PROG.

The key SELECT now scrolls the available parameters. By the key (+) , (-) the displayed values can be modified; to speed up parameter's variation press the key SELECT while "+" or "-" are pressed. Press key "ENTER/RESET" to validate the set values.

#### 13.1 - PROGRAMMING OF FUNCTIONS SETTINGS

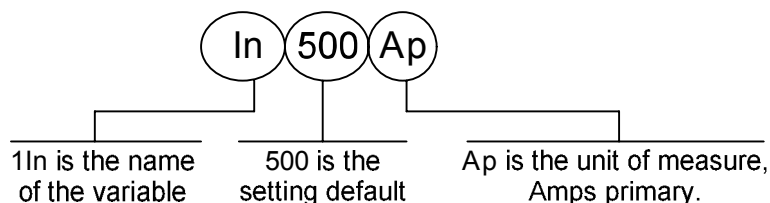

Mode PROG menu SETTINGS. (Production standard settings here under shown).

| Display   | Description   | Setting Range    | Step | Units           |
|-----------|---|------------------|------|-----------------|
| Fn 50 Hz  | System frequency  | 50 - 60          | 10   | Hz              |
| In 500A   | Rated primary current of CTs  | 1 - 9999         | 1    | A               |
| d> 0.15n  | Basic minimum pick-up level of low set phase differential element                                 | 0.02-0.2-Dis     | 0.01 | In              |
| 1R 2%     | Bias percentage in the zone $0,5 < I_R < P$   | 2-20             | 1    | %               |
| 2R 20%    | Bias percentage in the zone $I_R > P$   | 5-50             | 1    | %               |
| P 2.50    | Bias slope change point   | 1.00-3.00        | 0.01 | -               |
| 2H0.10d   | 2 <sup>nd</sup> Harmonic restraint level  | 0.10-1.00-Dis    | 0.01 | d               |
| I>5.00In  | Minimum pick-up level of overcurrent element  | 0.50-8           | 0.01 | In              |
| tI>3.00s  | Time delay of overcurrent element   | 0.05-9.99        | 0.01 | s               |
| do> 0.10n | Minimum pick-up level of Earth Fault element  | 0.01-1-Dis       | 0.01 | In              |
| tdo5.00s  | Time delay of Earth Fault element   | 0.05-9.99        | 0.01 | s               |
| BF --I -- | Selection of element controlling the Breaker Failure function                                     | d - I - do       |      | any combination |
| tBF 0.25s | Breaker Failure time delay  | 0.05-1.00        | 0.01 | s               |
| B1 ----do | Digital input B1 blocks the function selected   | d - I - do       |      | any combination |
| TRG d>    | Trigger for oscillography records is Internal (TRG=d>, I>, do>) or External via digital input B3. | Ext, d>, I>, do> |      | -               |
| NodAd 1   | Identification number for connection on serial communication bus                                  | 1 - 250          | 1    | -               |

The setting Dis indicates that the function is disactivated.



13.2 - PROGRAMMING THE CONFIGURATION OF OUTPUT RELAYS

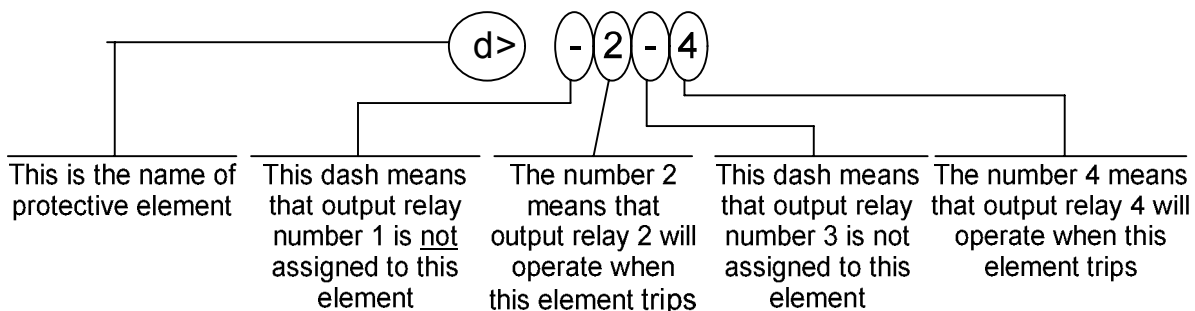

Mode PROG menu F→RELAY (Production standard settings here under shown).

The key "+" operates as cursor; it moves through the numbers corresponding to the four programmable relays in the sequence 1,2,3,4,(1= relay R1, etc.) and makes start flashing the information actually present in the digit. The information present in the digit can be either the number of the relay (if this was already associated to the function actually on programming) or a dot (-) if the relay was not yet addressed.

The key "-" changes the existing status from the dot to the relay number or viceversa.

After having programmed all the four relay, press "ENTER" to validate the programmed configuration.

| Display    | Description  |
|------------|--|
| d> 1---    | Differential element<br>operates relay R1, R2, R3, R4 as programmed (one or more)                                |
| l> ----    | Instantaneous Overcurrent element<br>operates relay R1, R2, R3, R4 as programmed                                 |
| tl> --3-   | Time delayed Overcurrent element<br>operates relay R1, R2, R3, R4 as programmed                                  |
| do> -2--   | Instantaneous Earth Fault element<br>operates relay R1, R2, R3, R4 as programmed                                 |
| tdo --3-   | Time delayed Earth Fault element<br>relay R1, R2, R3, R4 as programmed   |
| tBF ---4   | Breaker Failure function<br>relay R1, R2, R3, R4 as programmed   |
| FRes: Aut. | Reset of output relays after tripping is:<br>Aut. = Automatic Man. = Manually key Enter /Reset or via serial bus |



## 14. MANUAL AND AUTOMATIC TEST OPERATION

### 14.1 - Mode "TESTPROG" subprogram "W/O TRIP"

Operation of the yellow key activates a complete test of the electronics and the process routines. All the leds are lit-on and the display shows (TEST RUN). If the test routine is successfully completed the display switches-over to the default reading (dAxx.xxn). If an internal fault is detected, the display shows the fault identification code and the relay R5 is deenergized. This test can be carried-out even during the operation of the relay without affecting the relay tripping in case a fault takes place during the test itself. The display shows (TEST RUN) with the same procedure as for the test with W/O TRIP. Every 15 min during the normal operation the relay automatically initiates an auto test procedure (duration  $\leq 10$ ms). If any internal fault is detected during the auto test, the relay R5 is deenergized, the relevant led is activated and the fault code is displayed.

### 14.2 - Mode "TESTPROG" subprogram "WithTRIP"

Access to this program is enabled only if the current detected is zero (breaker open). Pressing the yellow key the display shows "TEST RUN?". A second operation of the yellow key starts a complete test which also includes the activation of all the output relays.



WARNING

Running the WithTRIP test will operate all of the output relays. Care must be taken to ensure that no unexpected or harmful equipment operations will occur as a result of running this test. It is generally recommended that this test be run only in a bench test environment or after all dangerous output connections are removed.

## 15. MAINTENANCE

No maintenance is required. Periodically a functional check-out can be made with the test procedures described under MANUAL TEST chapter. In case of malfunctioning please contact Microelettrica Scientifica Service or the local Authorised Dealer mentioning the relay's Serial No reported in the label on relays enclosure.



WARNING

In case of Internal Relay Fault detection, proceed as here-below indicated :

- ❑ If the error message displayed is one of the following "DSP Err", "ALU Err", "KBD Err", "ADC Err", switch off power supply and switch-on again. If the message does not disappear send the relay to Microelettrica Scientifica (or its local dealer) for repair.
- ❑ If the error message displayed is "E2P Err", try to program any parameter and then run "W/OTRIP".
- ❑ If message disappear please check all the parameters.  
If message remains send the relay to Microelettrica Scientifica (or its local dealer) for repair.

**16. ELECTRICAL CHARACTERISTICS**

- APPROVAZIONI : CE - RINA - File UL e CSA: E202083
- REFERENCE STANDARDS IEC 60255 - EN50263 - CE Directive - EN/IEC61000 - IEEE C37

- Dielectric test voltage IEC 60255-5 2kV, 50/60Hz, 1 min.
- Impulse test voltage IEC 60255-5 5kV (c.m.), 2kV (d.m.) – 1,2/50µs
- Climatic tests IEC 68-2-1 - 68-2-2 - 68-2-3

CE EMC Compatibility (EN50081-2 - EN50082-2 - EN50263)

- Electromagnetic emission EN55022 IND.ENV.
- Radiated electromagnetic field immunity test IEC61000-4-3 level 3 80-1000MHz 10V/m  
ENV50204 900MHz/200Hz 10V/m
- Conducted disturbances immunity test IEC61000-4-6 level 3 0.15-80MHz 10V
- Electrostatic discharge test IEC61000-4-2 level 4 6kV contact / 8kV air
- Power frequency magnetic test IEC61000-4-8 1000A/m 50/60Hz
- Pulse magnetic field IEC61000-4-9 1000A/m, 8/20µs
- Damped oscillatory magnetic field IEC61000-4-10 100A/m, 0.1-1MHz
- Electrical fast transient/burst IEC61000-4-4 level 4 2kV, 5kHz
- HF disturbance test with damped oscillatory wave (1MHz burst test) IEC60255-22-1 class 3 400pps, 2,5kV (m.c.), 1kV (d.m.)
- Oscillatory waves (Ring waves) IEC61000-4-12 level 4 4kV(c.m.), 2kV(d.m.)
- Surge immunity test IEC61000-4-5 level 4 2kV(c.m.), 1kV(d.m.)
- Voltage interruptions IEC60255-4-11
- Resistance to vibration and shocks IEC60255-21-1 - IEC60255-21-2

CHARACTERISTICS

- Accuracy at reference value of influencing factors 2% In for measure  
2% +/- 10ms for times
- Rated Current In = 1 or 5A - On = 1 or 5A
- Current overload 200 A for 1 sec; 10A continuous
- Burden on current inputs Phase : 0.01VA at In = 1A; 0.2VA at In = 5A  
Neutral : 0.015VA at In = 1A ; 0.35VA at In = 5A
- Average power supply consumption 8.5 VA
- Output relays rating 5 A; Vn = 380 V  
A.C. resistive switching = 1100W (380V max)  
make = 30 A (peak) 0,5 sec.  
break = 0.3 A, 110 Vcc,  
L/R = 40 ms (100.000 op.)
- Operation ambient temperature -10°C / +55°C
- Storage temperature -25°C / +70°C
- Humidity IEC 68-2-3 RH 93% Senza condensa a 40°C

Microelettrica Scientifica S.p.A. - 20089 Rozzano (MI) - Italy - Via Alberelle, 56/68  
Tel. (##39) 02 575731 - Fax (##39) 02 57510940

<http://www.microelettrica.com> e-mail : [ute@microelettrica.com](mailto:ute@microelettrica.com)

The performances and the characteristics reported in this manual are not binding and can modified at any moment without notice



17. CONNECTION DIAGRAM (SCE1492 Rev.3 Standard Output)

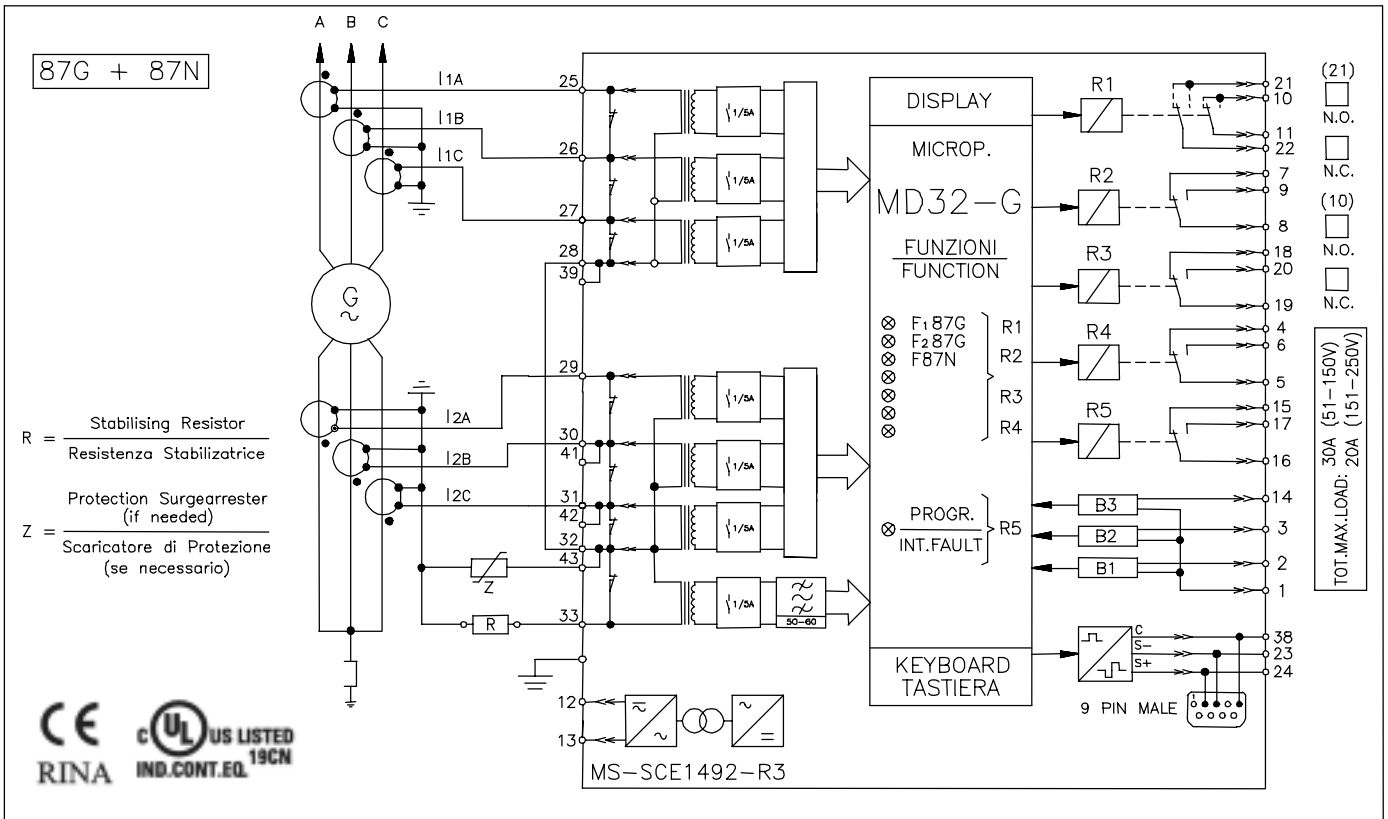

17.1 CONNECTION DIAGRAM (SCE1493 Rev.2 Standard Output)

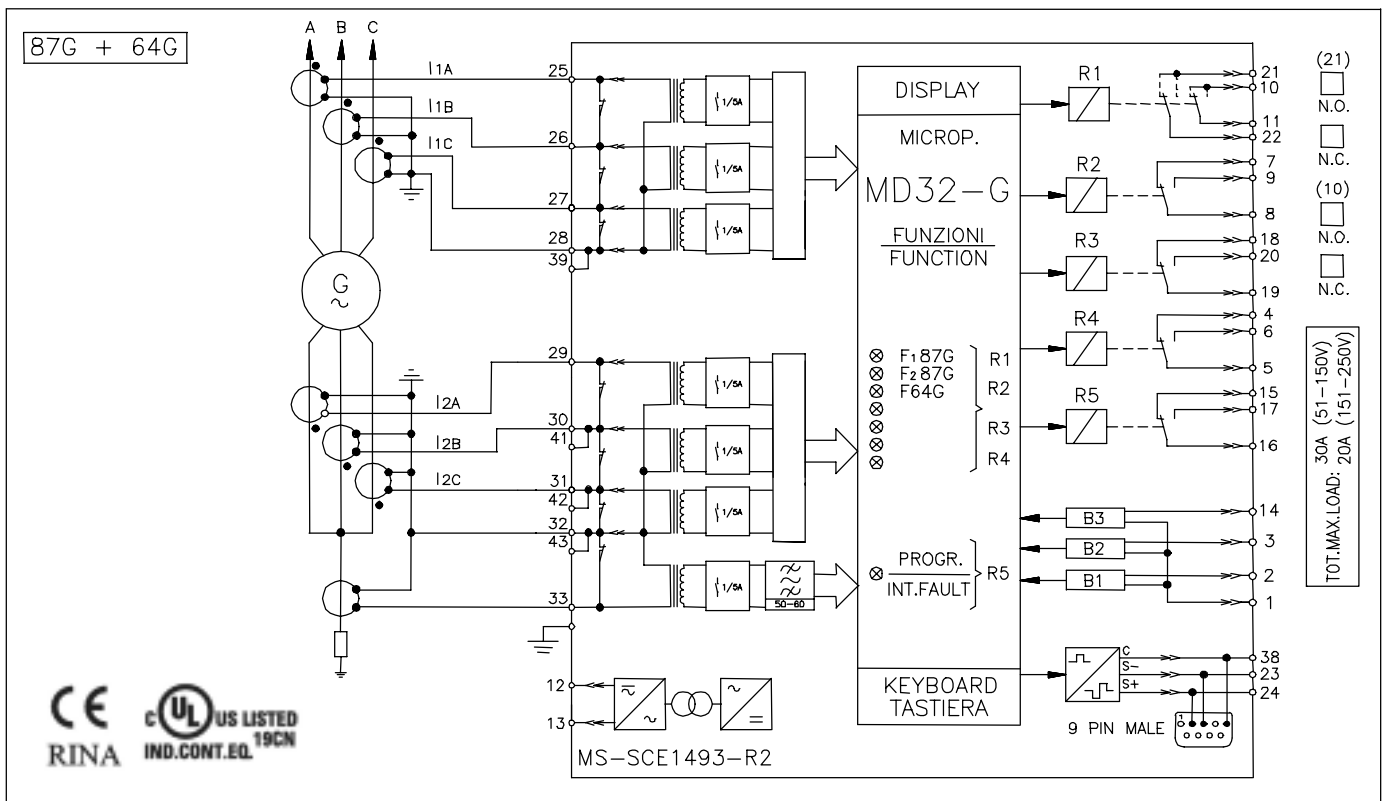



18. WIRING THE SERIAL COMMUNICATION BUS (SCE1309 Rev.0)

CONNECTION TO RS485

FIBER OPTIC CONNECTION

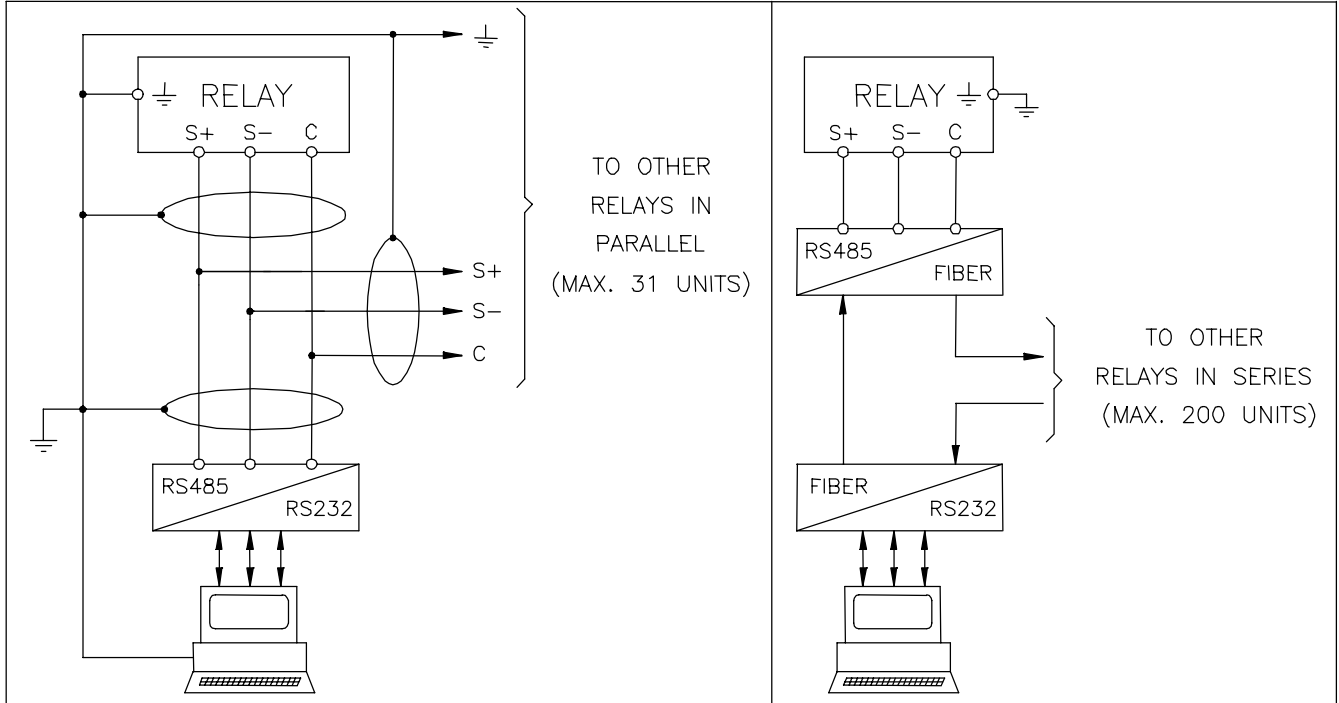

19. CHANGE PHASE CURRENT RATED INPUT 1 OR 5A

Phase current input can be 1 or 5A (movable jumpers on relay's card).

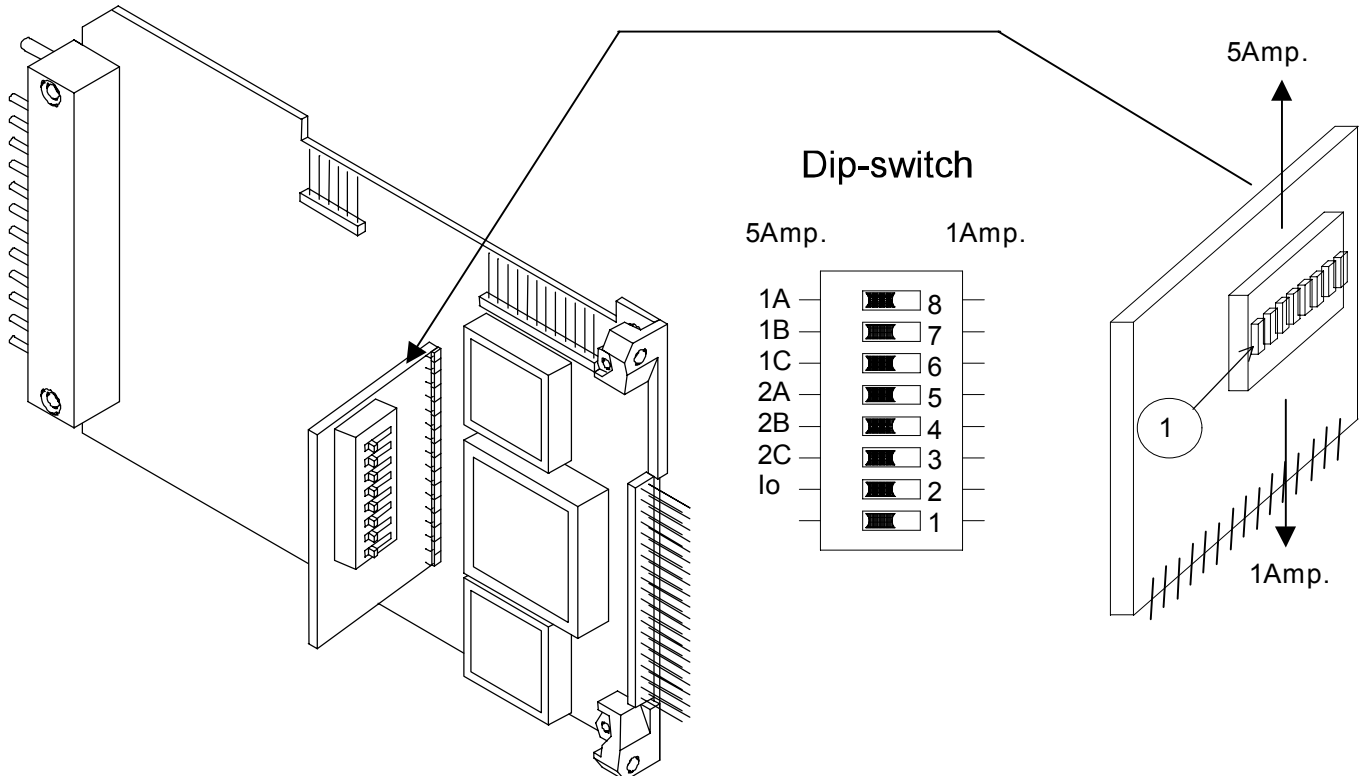



20. DIRECTION FOR PCB'S DRAW-OUT AND PLUG-IN

20.1 Draw-out

Rotate clockwise the screws ① and ② in the horizontal position of the screws-driver mark.  
Draw-out the PCB by pulling on the handle ③

20.2 Plug-in

Rotate clockwise the screws ① and ② in the horizontal position of the screws-driver mark.  
Slide-in the card on the rails provided inside the enclosure.  
Plug-in the card completely and by pressing the handle to the closed position.  
Rotate anticlockwise the screws ① and ② with the mark in the vertical position (locked).

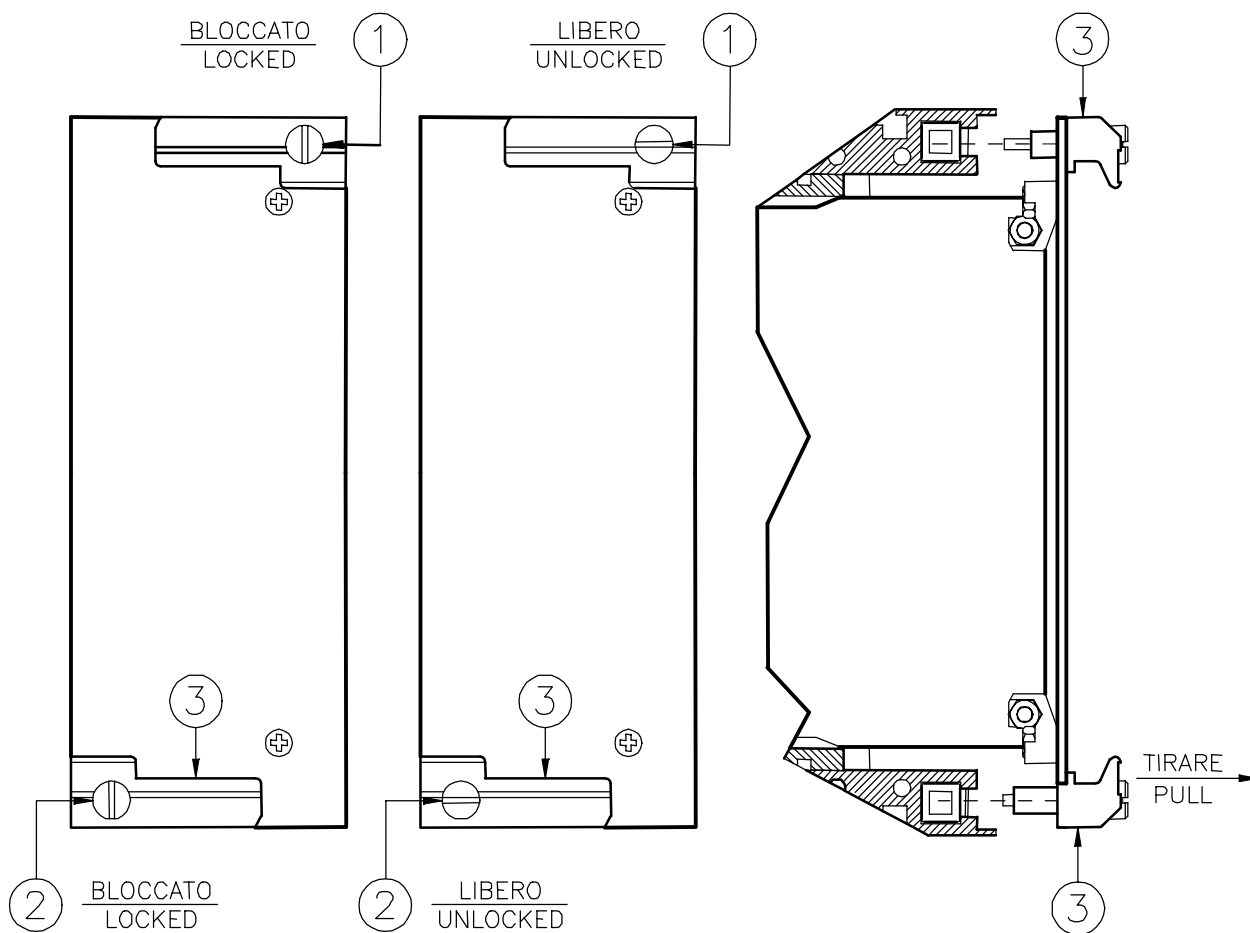



21. MOUNTING / OVERALL DIMENSIONS

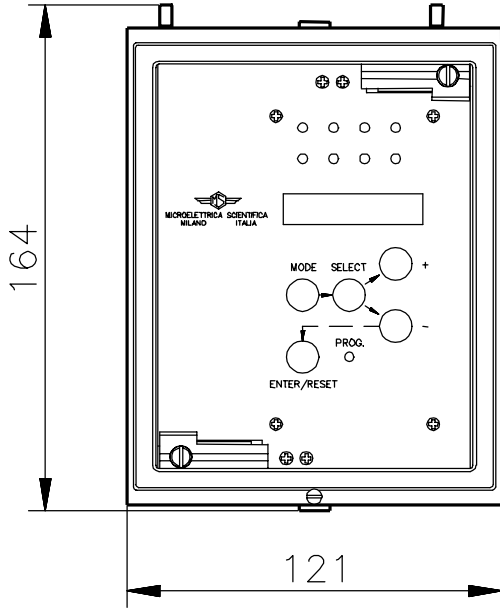

PANEL CUT-OUT 113x142 (LxH)

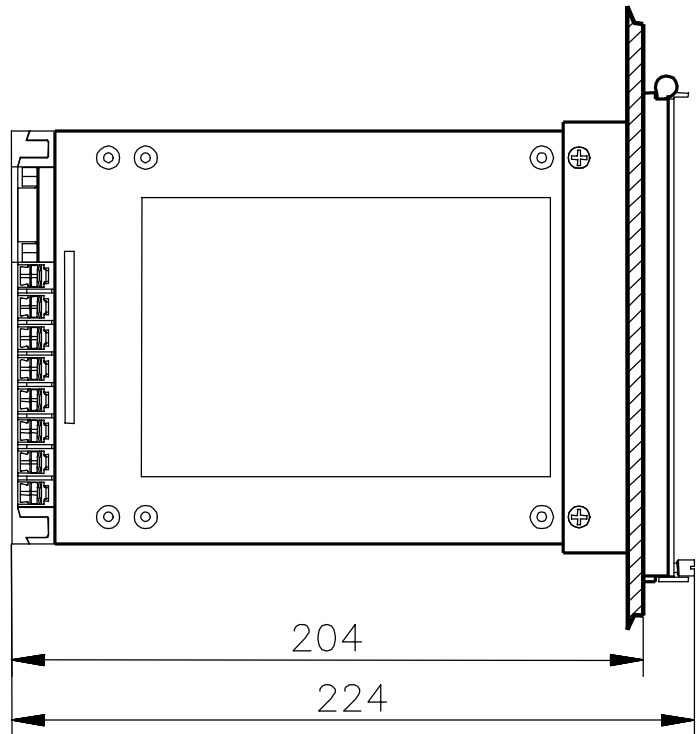

View of Rear Terminal Connection

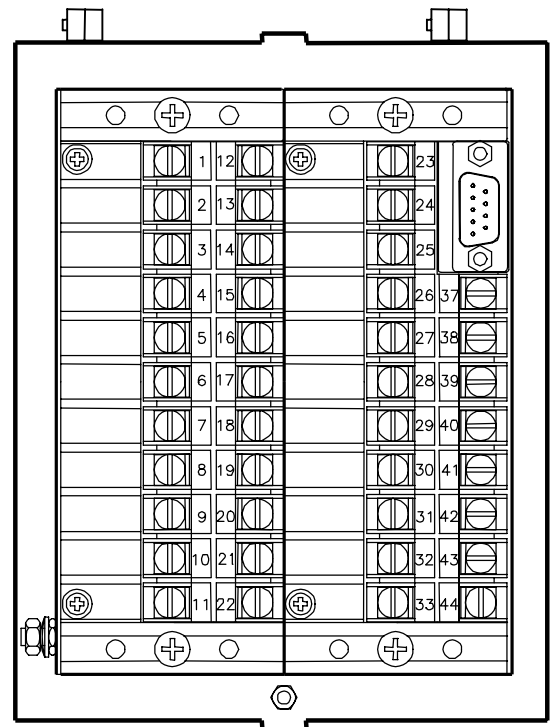
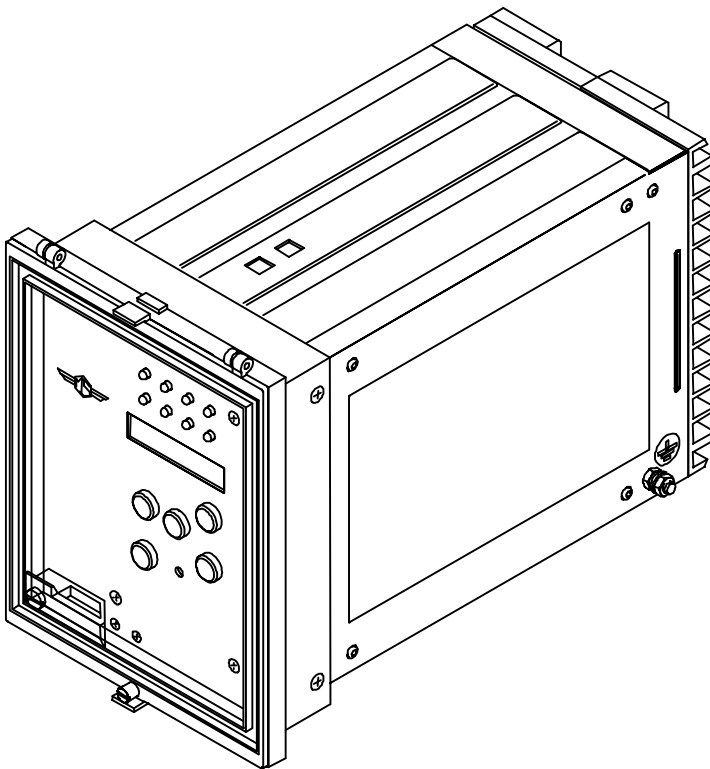



22. KEYBOARD OPERATIONAL DIAGRAM

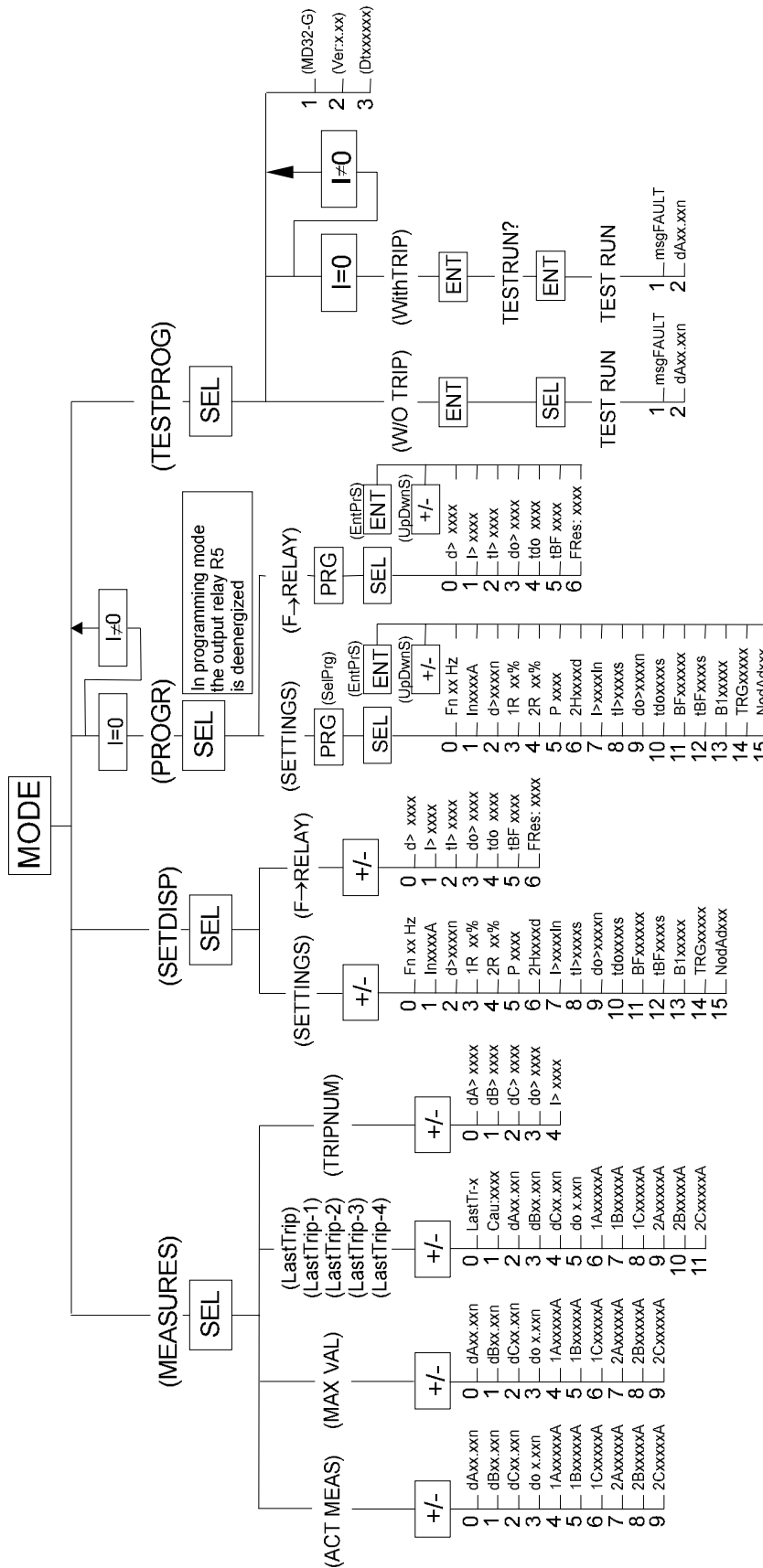



## 23. SETTING'S FORM

| Date :                         |               |       | Number Relay:   |          |   |                  |               |  |  |  |
|--------------------------------|---------------|-------|---|----------|---|------------------|---------------|--|--|--|
| RELAY PROGRAMMING              |               |       |   |          |   |                  |               |  |  |  |
| Default Setting                |               |       | Actual Setting  |          |   |                  |               |  |  |  |
| Variable                       | Value         | Units | Description   | Variable | Value   | Units            |               |  |  |  |
| Fn                             | 50            | Hz    | System frequency  | Fn       |   | Hz               |               |  |  |  |
| In                             | 500           | A     | Rated primary current of CTs  | In       |   | A                |               |  |  |  |
| d>                             | 0.15          | n     | Basic minimum pick-up level of low set phase differential element                                 | d>       |   | n                |               |  |  |  |
| 1R                             | 2             | %     | Bias percentage in the zone $0,5 < I_R < P$   | 1R       |   | %                |               |  |  |  |
| 2R                             | 20            | %     | Bias percentage in the zone $I_R > P$   | 2R       |   | %                |               |  |  |  |
| P                              | 2.50          | -     | Bias slope change point   | P        |   | -                |               |  |  |  |
| 2H                             | 0.10          | d     | 2 <sup>nd</sup> Harmonic restraint level  | 2H       |   | d                |               |  |  |  |
| I>                             | 5.00          | In    | Minimum pick-up level of overcurrent element  | I>       |   | In               |               |  |  |  |
| tI>                            | 3.00          | s     | Time delay of overcurrent element   | tI>      |   | s                |               |  |  |  |
| do>                            | 0.10          | n     | Minimum pick-up level of Earth Fault element  | do>      |   | n                |               |  |  |  |
| tdo                            | 5.00          | s     | Time delay of Earth Fault element   | tdo      |   | s                |               |  |  |  |
| BF                             | 1             | -     | Selection of element controlling the Breaker Failure function                                     | BF       |   | -                |               |  |  |  |
| tBF                            | 0.25          | s     | Breaker Failure time delay  | tBF      |   | s                |               |  |  |  |
| B1                             | do            | -     | Digital input B1 blocks the function selected   | B1       |   | -                |               |  |  |  |
| TRG                            | d>            | -     | Trigger for oscillography records is Internal (TRG=d>, I>, do>) or External via digital input B3. | TRG      |   | -                |               |  |  |  |
| NodAd                          | 1             | -     | Identification number for connection on serial communication bus                                  | NodAd    |   | -                |               |  |  |  |
| CONFIGURATION OF OUTPUT RELAYS |               |       |   |          |   |                  |               |  |  |  |
| Default Setting                |               |       | Actual Setting  |          |   |                  |               |  |  |  |
| Protect. Element               | Output Relays |       |   |          | Description   | Protect. Element | Output Relays |  |  |  |
| d>                             | 1             | -     | -   | -        | Differential element  | d>               |               |  |  |  |
| I>                             | -             | -     | -   | -        | Instantaneous Overcurrent   | I>               |               |  |  |  |
| tI>                            | -             | -     | 3   | -        | Time delayed Overcurrent  | tI>              |               |  |  |  |
| do>                            | -             | 2     | -   | -        | Instantaneous Earth Fault   | do>              |               |  |  |  |
| tdo                            | -             | -     | 3   | -        | Time delayed Earth Fault  | tdo              |               |  |  |  |
| tBF                            | -             | -     | -   | 4        | Breaker Failure   | tBF              |               |  |  |  |
| FRes:                          | Aut.          |       |   |          | Reset of output relays after tripping is:<br>Aut. = Automatic Man. = Manual | FRes:            |               |  |  |  |